

## FERRMED conference

# +FIRRST: THE SOLUTION FOR INTEGRATED FREIGHT TRANSPORT IN EUROPE

## INTERNATIONAL PILOT TEST STAKEHOLDERS' ALLIANCE FOR +FIRRST

### Dual use logistics capabilities across both civil and defence sectors

*PLEASE JOIN US ON THURSDAY, NOVEMBER 13, 2025, 9 AM  
RESIDENCE PALACE, WETSTRAAT, 155, B-1040, BRUSSELS*

### ESC, FERRMED, IRU AND UIRR JOINTLY WITH MCRIT LAUNCH A STAKEHOLDERS' ALLIANCE TO IMPLEMENT THE +FIRRST SYSTEM

The only way to achieve the EC targets of road traffic transfer to rail is to incorporate a system that can move isolated truck semi-trailers, swap-bodies and containers (ILUs) from and to different destinations in a fast, flexible, integrated rail-road system of transport (+FIRRST). It is a novel way of organising intermodal rail-road transport in the form of "Mobility as a Service" (MaaS).

+FIRRST is an integrated combined transport system fully aligned with the road (as the most flexible mode), able to meet in real time the daily demand in all locations (Origin/Destination of the transport chain and intermediate transfers).

Recently, the European Union faced critical challenges in military logistics, as existing infrastructure limitations continue to undermine rapid deployment, interoperability, and sustainability. In this context, the FERRMED Study on Traffic and Modal Shift Optimisation in the EU presents a comprehensive set of findings and criteria that could significantly contribute, additionally, to the objectives of the EU Military Mobility Package (2025–2030). By aligning with the framework of the DG MOVE and the EU Green Deal, FERRMED considers that the Study Conclusions, the +FIRRST System implementation and the related infrastructure criteria, can also enhance dual-use logistics capabilities across both civil and defence sectors, should the EU institutions choose to adopt them.

#### A strong stakeholders' Alliance is necessary to press forward with +FIRRST

1. The **primary purpose** of this Alliance is to **realise the pilot test of the +FIRRST** implementation in the catchment area of the two proposed rail routes:
  - a. Rotterdam-Antwerp-Brussels-Lille-Paris-Dijon-Lyon-Marseille-Montpellier-Barcelona.
  - b. Duisburg-Düsseldorf-Köln-Koblenz-Luxembourg-Metz-Nancy-Dijon-Lyon-Marseille-Montpellier-Barcelona.

Potential enlargement of the railway routes in the catchment area could be envisaged from: Lille to London; Duisburg to the North and East Germany and Poland; Metz to Saarbrücken and Frankfurt am Main; Lyon to Basel; Narbonne to Toulouse as well as

Barcelona to the South and West as the international track gauge is deployed on those routes.

2. The objective of the Alliance is to **involve** the stakeholders in the **realisation of the +FIRRST Pilot test**. In this regard, three sorts of stakeholder are envisaged: Promoters, Implementers and Supporters.

The promoters, together with the implementers and main supporters, will:

- I. Produce a detailed **definition of the +FIRRST Pilot test** (operation, software, infrastructure, rolling stock, etc.).
- II. Create a detailed, **3-phase implementation plan**:
  - 1st phase a) Removing cross-border barriers.
  - 1st phase b) Implementing +FIRRST using selected existing intermodal terminals.
  - 2nd phase. Implementing +FIRRST using selected existing intermodal terminals and additional +FIRRST terminals built in abandoned or semi-abandoned marshalling yards.
- III. Identify sources of **funding**.
- IV. **Specify actions** of the parties involved in the +FIRRST Pilot Test development and implementation.

3. **The membership** of the Alliance is as follows:

**Promoters:** ESC, FERRMED, IRU and UIRR with the help of MCrit.

**Implementers:** shippers, rail operators, road transporters, infrastructure managers, intermodal terminals, logistics operators, flow control centres, etc.

**Supporters:** Any organisations interested in the project, e.g.: associations related to transport and logistics, main ports, business associations, specialized media, involved member states, involved regions, etc.

Together with ESC, IRU, MCRIT, and UIRR, we are building a Stakeholders' Alliance to support the implementation of +FIRRST. We are proud to already have the support of over forty organizations, including ATEIA-OLTRA, BEST, CALSINA-CARRÉ, CERTIFYDOC, CIMALSA, S.A.DAMM, MENTRANS, NESTLÉ, LFP Perthus, DUISPORT, IN MOVE Rail Group, SEAT (Volkswagen Group), SERTRANS, SYNERGY, UETR, the Regions of Zuid Holland and Occitanie, and several others.



#### **Stakeholders' Alliance promoters**

*From left to right: Ralf Charley Schultze (UIRR Director General), Raluca Marian (IRU Director EU Advocacy and General Delegate of the Permanent Delegation to the EU), Joan Amorós (FERRMED President) and Godfried Smit (ESC Secretary General)*

## Transport performance in the EU Core Network (ECN)

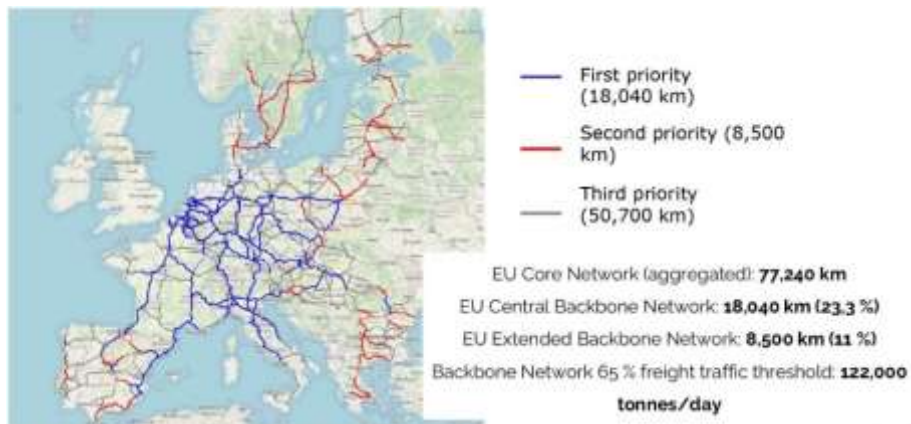

## EU strategic socio-economic hubs and Intermodal terminal new concept

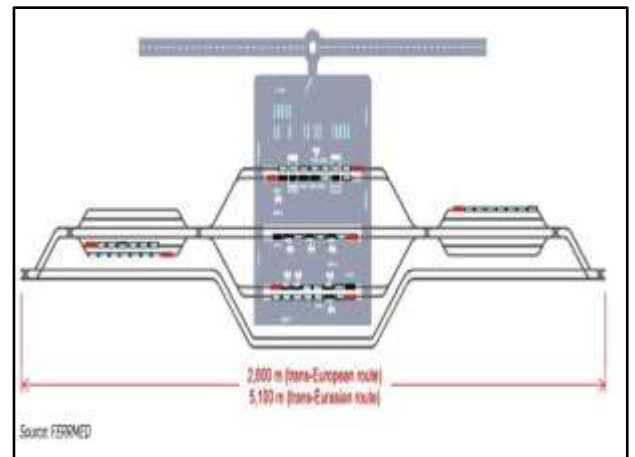
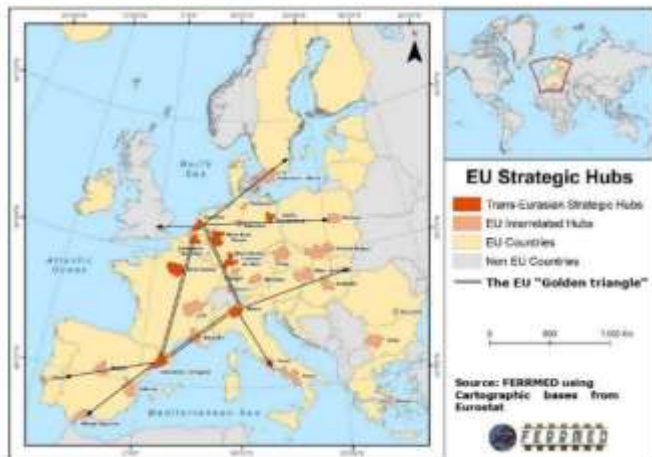

## +FIRRS international pilot test routes

**First phase**

**PILOT TEST**

**Second phase**

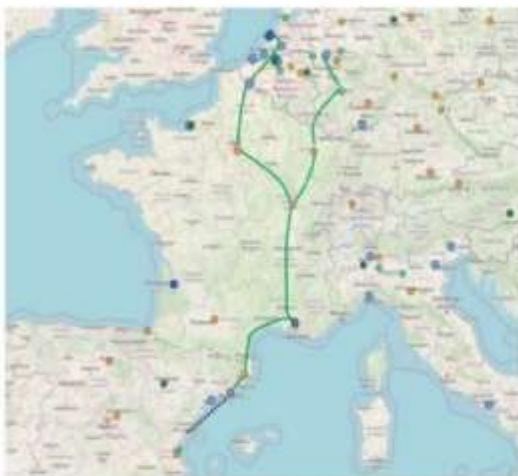

● Dead-End 740 m    ● Pass-through    ● New terminals in Marshalling Yards

## Tentative timeline

	2024	2025	2026	2027	2028
Constitution of the Stakeholders Alliance	██████████				
Creation of the task force for the test development	██████████				
Selection of funding sources	██████████				
Preparation of the documentation for the call for proposals	██████████				
Approval of the call for proposal		██████████			
Test Study development		██████████			
Approval of the test development plan			██████████		
Start of the First phase of the test				★	
Test development and control/assess "First phase"				██████████	
Preparation for second phase taking into account first phase assessment (as well as additional terminals)				-----	-----
Construction of +FIRRST terminals in existing marshalling yards				██████████	
Start of the second phase of the test					→

#### 4. FERRMED Study priority criteria versus EU's dual civil-military transport requirements.

FERRMED Study priority criteria are eventually aligned with the Military Mobility Package challenges:

- **Interoperability** with EU, EDA and NATO transport requirements.
- **Resilience**: multi-directional, redundant routes for emergency redeployment.
- **Sustainability**: -77% logistics environmental impact.
- **Readiness**: rapid terminal deployment for brigade-level operations.
- **Efficiency**: -51.5% in freight costs; €405,3B Investment + €230,9B NPV.

#### 5. Possible Considerations for DG DEFIS, EDA, EEAS and NATO

1. Endorse +FIRRST System as the reference dual-use model.
2. Prioritize infrastructure investment using FERRMED's Study corridor and terminal matrix.
3. Collaborate with the +FIRRST Stakeholders Alliance to ensure alignment and execution of the +FIRRST System Pilot Test.

Version: 30/10/2025

## PROGRAMME (Draft)

08.30	<b>Registration</b>
09:00	<b>Opening Session</b> <ul style="list-style-type: none"><li>- DG DEFIS Deputy Director-General</li><li>- DG MOVE, Mr Kristian Schmidt, Director Land Transport</li><li>- FERRMED, Mr. Joan Amorós, President</li><li>- SEDE, Ms Marie-Agnes Strack-Zimmermann (tbc).</li><li>- UIC, Mr. Philip van den Bosch, Deputy Director Freight.</li></ul>
09:40	<b>Presentation of the +FIRRST System</b> <ul style="list-style-type: none"><li>• Why +FIRRST?</li><li>• +FIRRST characteristics and base requirements</li><li>• Dual use logistics capabilities: civil and defence sectors.</li></ul> <p>- FERRMED, Mr. Eduard Gràcia, Financial Manager</p> <p><b>+FIRRST Explanatory video</b></p>
10:00	<b>Stakeholders' Alliance for +FIRRST system implementation</b> <ul style="list-style-type: none"><li>• +FIRRST system international pilot test</li><li>• Stakeholders' Alliance, objectives and main functions</li><li>• Stakeholders' Alliance members (Promoters, Implementers and Supporters)</li></ul> <p>- ESC, Mr. Godfried Smit, Secretary General (tbc)</p> <p>- FERRMED, Mr. Joan Amorós, President</p> <p>- IRU, Ms. Raluca Marian, Director EU Advocacy and General Delegate of the Permanent Delegation to the EU</p> <p>- UIRR, Mr. Ralf-Charley Schultze, Director General</p>
10:20	<b>Coffee break</b>
10:40	<b>Advantages and challenges of +FIRRST system</b> <p>(in marginal cost of transport, connectivity/route definition, flexibility, traceability, CO2/dangerous gases footprint, data base/real time information, paperless procedure, estimated time of arrival, dual use logistics capabilities: civil and defence sectors)</p> <p><b>Round table with representatives of the Alliance (Shippers/Logistics operators/Forwarders/Transport associations/Infrastructure Managers)</b></p> <ul style="list-style-type: none"><li>- ADIF Representative</li><li>- DSV Representative</li><li>- ESC, Mr Godfried Smit, Secretary General (tbc)</li><li>- METRANS Representative</li><li>- SEAT Representative</li><li>- SNCF Reseau Representative</li><li>- UETR, Mr. Marco Digioia, General Secretary</li></ul> <p>Moderator: IRU Mr. Federico Solfrini, Manager in the EU Goods Transport.</p>

**Round table with representatives of the Alliance (Terminals/Railway operators/Road transporters)**

- CALSINA CARRÉ, Ms Alba Carré CEO (tbc)
  - CAPTRAIN Representative
  - CFL multimodal Representative
  - CONTARGO, Mr. Andreas Mager, Managing Director. (tbc)
  - NAVILAND CARGO Representative
  - NOVATRANS, Mr. Nicolas Pontier, Commercial Manager.
  - SERTRANS, Ms. Anna Bosquet, Fair and events Manager
- Moderator: UIRR, Mr. Ralf-Charley Schultze, Director General.

**Round table concerning infrastructure dual use with the Stakeholders' Alliance and Military logistics representatives**

- CERTIFYDOC, Mr. Mario Scalabrino, Founder and CEO
  - DG DEFIS Logistics Representative
  - DG MOVE Representative
  - ERFA, Mr. Josselin Petit, Secretary General (Acting) (tbc)
  - ESC Representative
  - FERRMED, Mr. Valentí Ambròs, FERRMED Advisor
  - IRU, Mr. Federico Solfrini, Manager in the EU Goods Transport
  - UIRR, Mr. Ralf-Charley Schultze, Managing Director.
- Moderator: MCrit, Mr. Efrain Larrea, Logistics Director.

13:40

**Closing Remarks**

- CER, Mr. Alberto Mazzola, Executive Director.

13:50

**End of the Conference/Networking Lunch**

Version: 24/10/2025

Language of the conference:  
**English**

**FERRMED, a.s.b.l.**

Rue de Trèves, 49 B7

B-1040 Brussels

Phone: +32 2 230 59 50

F : +32 2 230 70 35

E : [bureau@ferrmed.com](mailto:bureau@ferrmed.com)

[www.ferrmed.com](http://www.ferrmed.com)

## Stakeholders' Alliance promoters



And the support of

## Stakeholders' Alliance members

Updated on 9<sup>th</sup> October 2025





With the collaboration of:



**FERRMED, a.s.b.l.**

Rue de Trèves, 49 B7

B-1040 Brussels

Phone: +32 2 230 59 50

F : +32 2 230 70 35

E : [bureau@fermed.com](mailto:bureau@fermed.com)

[www.fermed.com](http://www.fermed.com)