



FERRMED

Promotion du Grand Axe Ferroviaire de marchandises
Scandinavie-Rhin-Rhône-Méditerranée Occidentale A.S.B.L

FERRMED FREIGHT LOCOMOTIVE CONCEPT STUDY

By:

ALSTOM

 **Faiveley** S.A.

vossloh



Colegio Oficial de
Ingenieros Superiores Industriales
de la Comunidad Valenciana

Engineers
Industrials de Catalunya

A⁺



UNIVERSITAT POLITÈCNICA
DE CATALUNYA



TABLE OF CONTENTS

1	INTRODUCTION.....	4
1.1	What is FERRMED?	4
1.2	FERRMED Objectives	5
1.3	The FERRMED Standards.....	5
2	EXECUTIVE SUMMARY	7
3	EUROPEAN NETWORK CHARACTERISTICS	9
4	INTEROPERABILITY AND CROSS-ACCEPTANCE	12
4.1	Interoperability	12
4.2	ERTMS.....	18
4.3	Cross-Acceptance.....	21
5	STATE-OF-THE-ART WORLDWIDE LOCOMOTIVES	23
6	REQUIRED STARTING TRACTIVE EFFORT AND POWER TO HAUL “FERRMED TRAINS”	27
6.1	Why trains of 3.600t up to 5.000t?	27
6.2	Maximum admissible trains gross weight	29
6.3	Starting tractive effort required to haul FERRMED trains.....	36
6.4	Power required to haul FERRMED trains at a defined speed	37
6.5	General conclusions:	39
7	TECHNICAL PARAMETERS TO HAUL HEAVIER AND LONGER TRAINS	40
7.1	Power supply	40
7.2	Adhesion	50
7.3	Coupling: Automatic freight coupler	51
7.4	Multiple traction	56
7.5	Brake system	58
8	CHARACTERISTICS TO ENSURE THE COMFORT, SAFETY AND SECURITY TO THE DRIVER.....	70
8.1	Driver’s cab.....	70
8.2	Driving Advice Systems and other help devices.....	74
9	ENVIRONMENTAL ASPECTS	78
9.1	Energy efficiency.....	78
9.2	Exhaust emissions	82
9.3	Noise emissions.....	86
9.4	Recycling materials.....	89
10	TRANSITION PERIOD	91
11	CONCLUSIONS AND RECOMMENDATIONS	93
12	SUMMARY: HOW IS FERRMED FREIGHT LOCOMOTIVE?	95



1 INTRODUCTION

1.1 What is FERRMED?

At the dawn of the 21st century, the European Union faces extraordinary challenges. The urgent need to increase the efficiency and competitiveness of our economy – in view of fierce competition from abroad – coupled with the need to bring cohesiveness to an enlarged Union of twenty seven member states, with almost 500 million inhabitants, and to ensure the sustainability of our environment, society and values, call for decisive measures.

Central to these challenges is freight transport. We need a freight transport system that is more efficient, effective, competitive, environmentally friendly, reliable, encompassing and safer than the system we have today.

Until the first half of the 20th century, rail freight transport was one of the main pillars of the European transport system. This changed in the second half of the 20th century, due to the growth in road transport. The strategic importance of rail freight transport has resurfaced due to its relatively larger freight carrying potential capacity and its efficiency in terms of energy use, low greenhouse emissions and generally low environmental impact, as recognized by the public and the private sector.

Recognizing the necessity to shift freight transport from road to railways as well as to achieve system interoperability, the European Union has issued a significant amount of legislation and regulations since the 1990s on rail transport policies and standards that is still in the process of being adopted by Member States.

The private sector has an important role to play in the process of reconstructing a rail freight transport system that responds more efficiently to the needs of trade, industry and services, as well as instrumental in the adoption and implementation of harmonized rail freight policies and standards in the European Union.

Having these challenges and alternatives in mind, FERRMED was founded in Brussels on 5 August 2004 as a non-profit association which seeks to enhance European competitiveness and sustainable development by improving rail freight transport. Today FERRMED is supported by 143 members, including key business institutions and private companies from all over Europe and North Africa.



1.2 FERRMED Objectives

Consistently with the objectives pursued by the European Union, FERRMED advocates, supports and promotes the following main objectives:

- To promote the creation of the Great Axis Rail Freight Scandinavia – Rhine – Rhone – Western – Mediterranean.
- To promote the implementation of the FERRMED Standards in the EU and neighboring countries rail networks.
- To improve intermodal freight transportation – railway being one of the modes – all over the EU and its neighboring countries.
- To improve ports and airports rail connections with their respective hinterlands.
- To contribute to a more sustainable overall development through the reduction of pollution and green house gas emissions.
- To stimulate European competitiveness through the continuous improvements of the global/multimodal chain of added value in the European Union and its neighboring countries.

1.3 The FERRMED Standards

Interoperability is the key to improve the competitiveness of rail freight in the EU. To this end, FERRMED proposes a set of standards which, albeit ambitious, could be gradually implemented:

1. A EU reticular and polycentric network with a great socio-economic and intermodal impact (comprising three or four great North-South and three great East-West Trans-European axes, jointly with their corresponding subsidiary main feeding lines).

The main branches of the axes should have:

FERRMED FREIGHT LOCOMOTIVE CONCEPT STUDY



- a. Electrified (preferably 25.000 volts) conventional lines with double track, axle load of 22.5 ÷ 25 tones, giving same priority to common freight trains than passenger trains.
 - b. High performances parallel lines available for exclusive or preferential use of passenger and light fast moving freight transportation properly connected with the main airports network.
2. Width of the tracks: UIC.
 3. UIC C loading gauge.
 4. Freight trains length reaching 1.500 meters with loading capacity from 3.600 to 5.000 tones.
 5. A maximum slope of 0.012 and limited ramps length.
 6. Huge cities by-passes for freight.
 7. Availability of a network of intermodal polyvalent and flexible terminals with a high level of performance and competitiveness based in the harbors and main logistics nodes of the great axes.
 8. Usable length of siding and terminals for 1.500 m trains.
 9. Unified management, monitoring and tracking (through ITS) systems by main branches of every great axis.
 10. ERTMS system with “two ways working” along the tracks.
 11. Availability of capacity and traffic schedules for freight transportation “24 hours a day and 7 days a week”.
 12. Harmonization of the administrative formalities and the social legislation.
 13. Transport system management shared with several rail operators (free competition).
 14. Favorable and homogeneous fees for the use of infrastructures, bearing in mind the socioeconomic and environmental advantages of the railway.
 15. Rail freight management philosophy based on the principles of the “R+D+4i” (Research, Development, innovation, identity, impact, infrastructures) in the rail freight network, as an integral part of the global chain of added value.
 16. Reduction of the environmental impact of the freight transporting system (particularly noise, vibration and CO2 emissions) as a result of the retrofitting old railway rolling stock, infrastructural solutions where needed, and an increase in the share of the rail in long distance land transport up to 30 ÷ 35%.
 17. Locomotive and wagon concepts adapted to FERRMED Technical Standards.

FERRMED FREIGHT LOCOMOTIVE CONCEPT STUDY



2 EXECUTIVE SUMMARY

The final objective of FERRMED Standards, of FERRMED Freight Locomotive Concept and FERRMED Wagon Concept is to increase the competitiveness and profitability of the freight transport in Europe to reduce logistics costs of the companies making them more competitive.

To achieve this purpose, FERRMED proposes:

- To increase the length and the load of the train to 1500m and 3600 ÷ 5000 tons with 22.5 tons per axle (in the future 25 t/axle)
- To allow the free circulation of freight trains at least along the European Rail Freight Core Network. Due to the barriers (legal, political and physical) that traditionally the countries have made to international rail traffic; interoperability is one of the main issues that European locomotives should solve.

First reflection is, that requirements needed in Europe are completely different than other countries like US, Australia, China,...due to different type of topography, distribution of the cities, costs, infrastructure...so, the rolling stock should be designed based on European problems.

The **objective of this study** is to define the minimum parameters that the EU locomotives should have to fulfil the FERRMED Standards, particularly long and heavy trains. The here called “FERRMED trains” are trains 1500m long and with a load of 3600 ÷ 5000 tons. They have to be able to start on maximum slope from static state (slope of 12 ‰) according with the FERRMED Standards.

The items analyzed are: starting tractive effort, adherent weight, adhesion, power required and power supply, coupling, multiple traction, brake system, interoperability, comfort and safety of the driver, signalling, noise, emissions and energy efficiency among others.

More power does not mean more load. More powerful locomotive allows operations at higher speed and acceleration, but there are other parameters that define if a load can be hauled or not and if this train can start or not. These parameters are:

- Gradient of the slopes
- Type of coupling
- Adhesion
- Starting tractive effort of the locomotive
- Adherent weight of the locomotive/s.

Starting tractive effort required to start and to haul “FERRMED trains” in slopes of 12‰ are between 600kN and 800kN depending on the total tons transported. That is double than current European locomotives have (300kN have Bo-Bo locomotives, 400kN have Co-Co locomotives), therefore, it will be necessary more than 1 locomotive to haul “FERRMED trains”.

Adherent weight of the locomotives increases with the number of motorized axles of the locomotive and with the axle load. Under European infrastructure constrains (maximum 22,5 t/axle) at least 12 axles are required to haul “FERRMED trains”.

Therefore, although in terms of purchasing costs, operational costs or maintenance costs... it will be more competitive to operate “FERRMED Trains” with just a powerful locomotive; it is necessary at least 2 Co-Co locomotives or 3 Bo-Bo locomotives to start such trains of 3600 t ÷ 5000t in slopes of 12‰.

Limitations of **adhesion** by the Infrastructure Administrations should be revised and updated. Thanks to new technologies, current and future locomotives can achieve better adhesion



coefficients than former ones with just electromechanical adhesion control systems. FERRMED recommends accepting at least an adhesion coefficient (μ_0) of 33%.

The **total power** required to haul “FERRMED trains” in an adequate speed will round 7.000 KW to 10.000 kW. But, it is enough that FERRMED Locomotive has 3.500 KW to 5.000 KW with the capacity to operate in multiple traction. Anyway, more powerful locomotives have advantages respect speed and acceleration.

Power can be supplied by the catenary, by diesel motors or by any new energy supply technology feasible in the future: fuel-cell, batteries ...

Couplings with higher resistance as the current screw coupling are also required. Automatic coupling is the best option in terms of resistance and safety but also to allow longer trains than current European ones. The coupling should be universal for all types of European locos and wagons. It should also be compatible with Russian coupling and during the transition period, it should be compatible with current screw coupling.

FERRMED locomotive should be **interoperable**, so they should meet following requirements:

- Fulfill all applicable TSI, European Directives and national-specific norms
- Be homologated for all countries where it will operate
- Track gauge: 1435mm
- Diesel or electrical multi-tension locomotive at least until the whole Freight Core Network has the same voltage, 25kV
- Equipped with European Central Driver Desk.
- ERTMS should be the communication system between train and rail, replacing the system used in each country actually. FERRMED Locomotive should be able for ERTMS level2: equipped with ETCS and GSM-R radio system.

FERRMED locomotive must allow **distributed multiple traction**. The communication between locomotives can be wireless (via radio) or wire-connected.

FERRMED locomotive should have the capability of communication with the wagons.

Brake system must be E-ECP (Enhanced-Electronically controlled pneumatic system)

FERRMED locomotive should ensure the comfort of the driver but also the safety of driver and load.

FERRMED locomotive should have also a commitment with the **environment** including all innovations to reduce noise and exhaust emissions but also the energy consumption. Locomotive must be recyclable as much as it could be possible (around 90 ÷ 95%), producing minimum pollution as possible and be silent and efficient as much as it could be possible.

Many of the innovations of the FERRMED Freight Locomotive Concept are already developed but still not implemented. The total implementation of some of them like ERTMS, automatic coupling, E-ECP brake, distributed multiple traction via radio or wire-connected... will require still some years. During this **transition period**, rolling stock should incorporate gradually the innovations. For example, the automatic coupler has to be compatible with current screw couplers installed in thousand of wagons; or locomotives should have on-board ETCS but also national safety systems until ERTMS is full extended over the European Rail Freight Core Network.

FERRMED FREIGHT LOCOMOTIVE CONCEPT STUDY

3 EUROPEAN NETWORK CHARACTERISTICS

Before analyzing how should be future European locomotives to have a competitive European rail freight transport, a short description about European network situation and the worldwide state-of-the-art locomotives should be made to compare with other countries and take from them characteristics that can be applied in Europe.

Depending on which characteristics have a country or region, it's about building the most convenient structure for it. If all countries had same characteristics, there would be only one solution. The characteristics can be economical (maybe there are less tax if the transport is by rail than by road or in USA where the low cost of fuel gives an advantage to diesel locomotives), political (the government interest in this type of transport), geographical, historical, social,...

With that in view, there is a basic description on each region where rail freight transport plays an important roll.

Following table shows the rail freight traffics in different countries

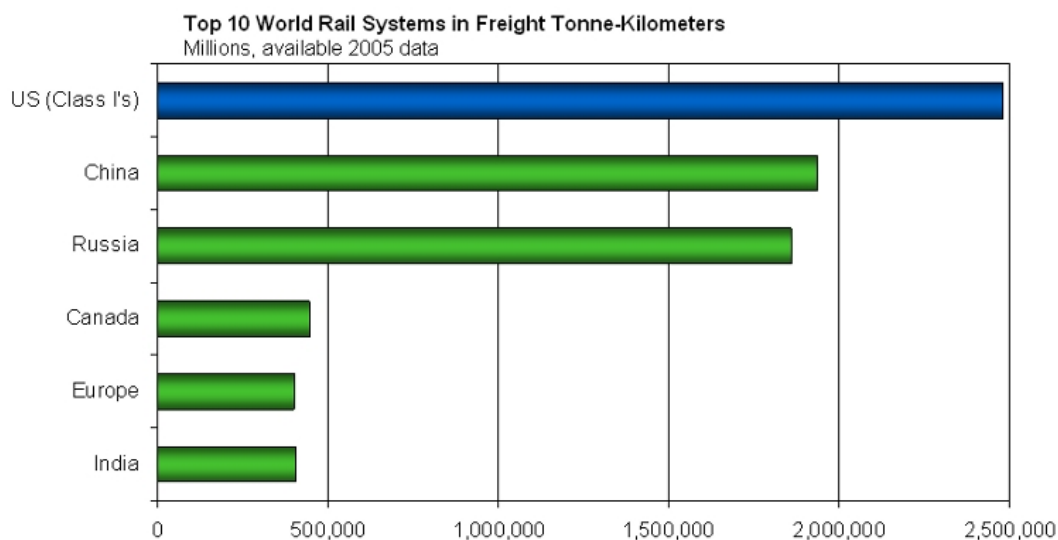

Source: World Bank Railways Database, May 2007.

Figure 1

USA, China and Russia are the countries where more ton-km are transported by rail.

Europe has less ton-km than Canada and the population of Canada is around 34 million while in Europe the population is around 500 million persons.

In Europe only 14% of the surface transport is made by railways and inside Europe there are big difference between countries, In Eastern Europe this percentage is relative big compared for example with Spain, where only 4% is moving by rail. Following table shows these differences.

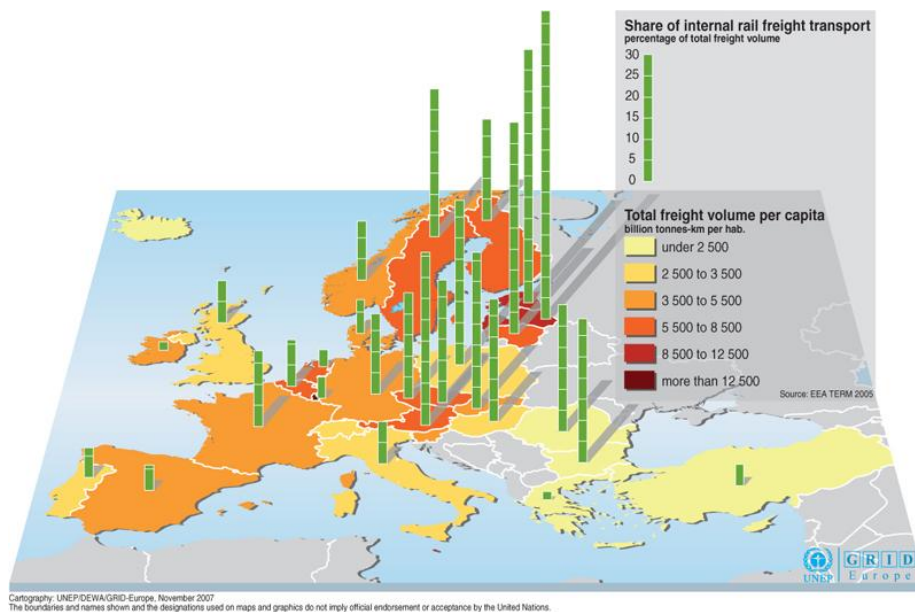

Figure 2

Certainly, Europe has many differences between countries (voltage, gauges signaling,...) compared to USA or China that harm the interoperability along Europe as required by FERRMED.

The poor situation of the European rail freight transport is due to diverse factors that can be summarized in:

1. **Political barriers:** the different European Governments consider rail freight transport as a sub-product of the railways giving priority to passenger transport in most of the cases. Taking examples from other countries where this type of transport is going well, we can mention USA (40% freight by railroad), Russia or China (50% freight by railroad). It has also to be mentioned that in these countries distances are much longer than in Europe, making much more interesting the railroad freight transport.
2. **Infrastructures:**
 - As consequence of point 1, there are not dedicated freight corridors in Europe or lines where freight transport has priority over passenger transport. Despite the needed huge investments, it is necessary in areas with great population, where rail network is saturated with passenger trains, to have by-passes or corridors for freight transport. These “dedicated” freight corridors have also the advantage that allow much more trains because all the average speed of freight trains is similar improving the trip time, the slot occupation and so, the volume of goods transported.
 - Lack of efficient rail access to intermodal terminals like ports that allow the transfer of goods between modes of transport
 - Length of stations, marshalling yards, terminals and overtaking tracks that limit also the length of the train. Some European countries allow 750m but the length of the train in most of them is around 450m or even lower. In USA, South Africa



and China are running trains of 2500m and in Australia 3000m that is, five times more than in Europe.

- Maximum axle-load allowed in Europe is 22,5t/axle or even lower in some corridors while USA allows 32,5 t/axle (almost 50% more).

As it has been seen comparing Europe with countries with a high percentage of rail freight transport, it is necessary to transport more tons per train to have a competitive and efficient rail freight transport. That can be done increasing the length of the train but also the axle-load. Some countries like Sweden have already corridors with 25t/axle and other like Germany, France or The Netherlands are trying to run trains of 1000m

FERRMED proposes to keep 22.5 t/axle in the conventional existing lines and to look for 25 t/axle in the new ones (10% more freight) and trains of 1500m starting by unifying the length of the train to 750m for all Europe.

3. **Interoperability barriers between countries:** there are different regulation but also other physical barriers like different voltage, radio frequency, track gauges, signaling systems, load gauges,

Following point will explain the current interoperability barriers in Europe and which of them are solved by the rolling stock.



4 INTEROPERABILITY AND CROSS-ACCEPTANCE

4.1 Interoperability

Interoperability is the ability of two or more systems or components to exchange information and to use this information; Interoperability gives the possibility to operate in several countries with the same rolling stock, locomotives and freight wagons.

Nowadays, many “physical” and “legal” differences between neighboring countries avoid the interoperability of the rolling stock. FERRMED standards promote the total interoperability around Europe to facilitate European rail freight transport in a safer and cheaper way.

European Commission, European countries and manufacturers are working since some years to improve the interoperability of the European rail network. For example, it has been created the *European Railway Agency (ERA)* to regulate the existing chaos. ERA is responsible of developing the *Technical Specification of Interoperability, TSI*, which are the new norms that interoperable rolling stock should fulfill. Some TSI are already mandatory but some of them are still in development and it will take some years to be completely operative.

For freight transport, rolling stock should meet following norms to be interoperable:

- Conventional Rail Rolling Stock TSI: Beginning 2009 was finished the draft version and middle of 2010 will come into force for locomotives and conventional rolling stock (up to 200km/h)
- Freight Wagon TSI: since July 2006 is mandatory
- Horizontal TSI: Noise TSI, Freight TSI, Crash TSI...
- Other European Directives that affect the rail rolling stock: Fire, Emissions (NRMM 2004/26/EC)
- Other country-specific norms that the rolling stock should meet to be certified in these countries. In Spain this norms are the ETH and are mandatory since beginning 2010.

Although rail manufacturers have solved some interoperability problems with innovations on the rolling stock, still now, in many cross-border operations driver and locomotives should be changed. Most of the freight wagons can run along Europe crossing countries if they are certified for it. The only interoperability problem related with the wagon is the track gauge or track width. For example, in the Spanish-French border where the track width changes from 1668mm to 1435mm, well the load is changed also to other wagons, or well, wagons remain the same but their axles should be changed.

Following points will give a vision of the main interoperability barriers that European rail network has and how can be solved with the current technology.

4.1.1 Different electrification

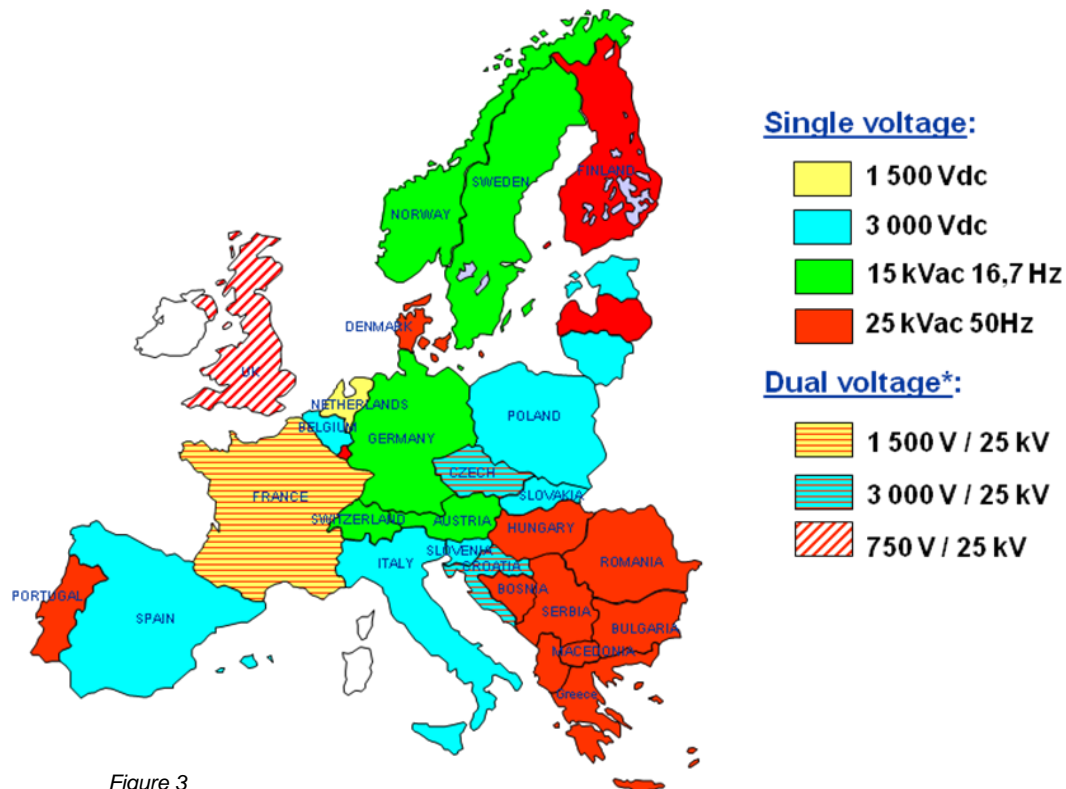

Figure 3

As it can be seen on the map, there are many different types of voltage around Europe; even some countries have two of them.

Nowadays this barrier is overcome thanks to improvements in rolling stock. Diesel locomotives but also multi-system electrical locomotives can operate in different countries.

Anyway FERRMED proposes for the big freight corridors to use 25kV and 50 Hz. The higher the voltage, the lowest current intensity required which lowers the energy cost, and the thermal losses.

Big countries like USA or Australia, with extensive areas without population and long travel distances, chose the no-electrification of the large freight corridors due to economical reason. There, diesel locomotives are used for transporting goods.

4.1.2 Different Track Gauges

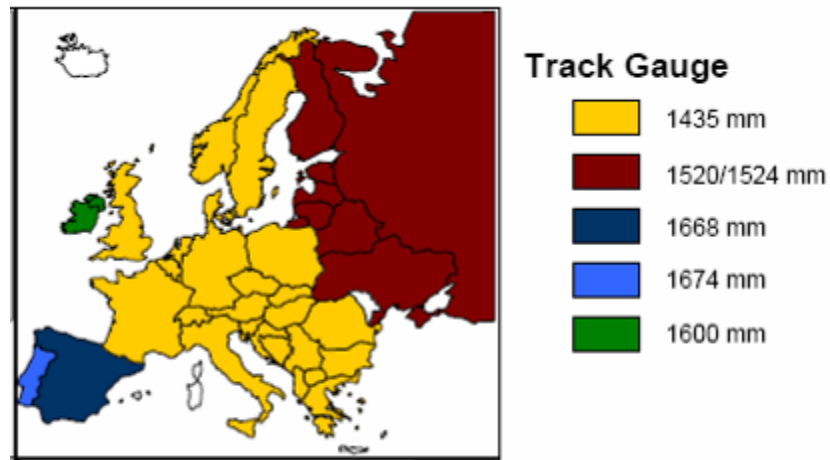

Figure 4

In Europe there are different track gauges:

- 762 mm: It is used in some lines of Austria, Slovakia, Czech Republic and Balkan countries.
- 1.000 mm: Also called “metric gauge”. It can be found principally in mountainous countries like Spain, Switzerland or Austria.
- 1.435 mm: Also called “standard gauge” or “UIC gauge”. It is used in most Europe
- 1.520 / 1.524 mm: Also called “Russian gauge”. IT can be found in Russia, Finland, and in countries of the all Soviet Union.
- 1.600 mm in Ireland
- 1.668 / 1.674 mm: Also called “Iberian gauge” because it can be found in Spain and Portugal.

The track gauges of 762mm and 1.000mm can be found in very specific lines and are not very relevant for the total of the rail freight transport.

But, Iberian and Russian gauges are barriers for the cross-borders traffics inside Europe.

Until the technology for variable wide bogies in freight transport (locomotives and wagons) is available, like it is already available in passenger transport, the solutions are to change the locomotive at the border and well to move the load to other wagons or well, to change the axles of the wagons. These solutions solve the problem on the border but require plus operations that make the transport slower, more complicated and more expensive. In definitive, the cross-border freight rail transport loses competitiveness respect the road.

FERRMED’s standards propose only one type of track width (1435mm) along FERRMED Great Axis to simplify cross-border operations.

4.1.3 Different Loading Gauge

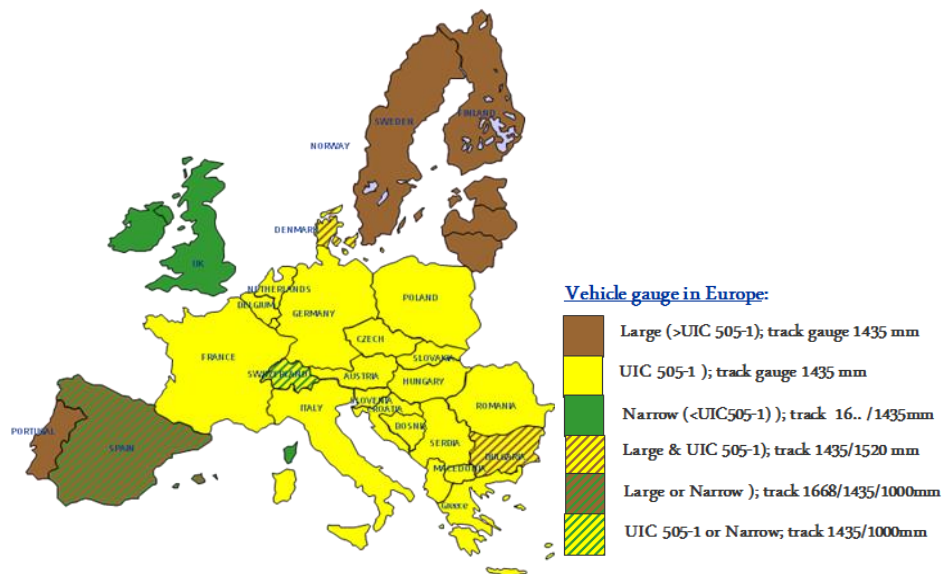

Figure 5

The gauge of the train is an important parameter to consider mainly operating on tunnels and bridges. It also affects to the clearance regarding other objects, like stations, platforms or other trains when crossing. Major part of European countries meet UIC 505-1 but there are others like Spain Portugal or Great Britain that have their own rules.

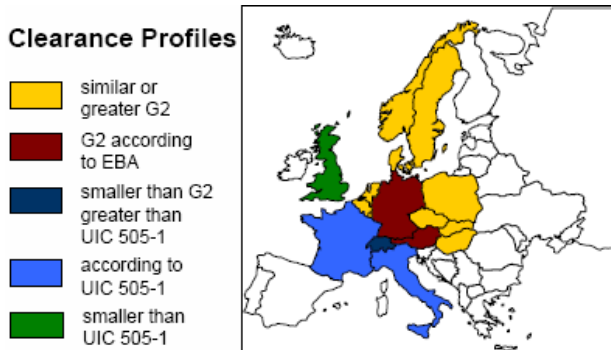
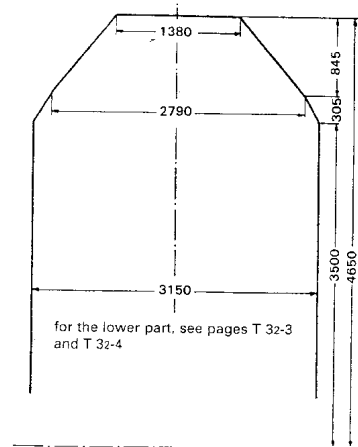

Figure 6

Figure 7



FERRMED proposes gauge UIC-C because it is the biggest one in Europe and allow the transport of all kind of containers and swap-bodies.

4.1.4 Direction of Running

As it is shown in the figure, the direction of running is not the same in each European country. This interoperability barrier is solved by the European Driver Cab (see chapter 7.2), taken by FERRMED project, presents a new driver desk where the driver is seating in the center of the cabin, solving the problems due to different direction of running.

European Driver Cab has been developed by most of the European rolling stock manufacturers under the coordination of UNIFE in the FP6 project EUDD+ .

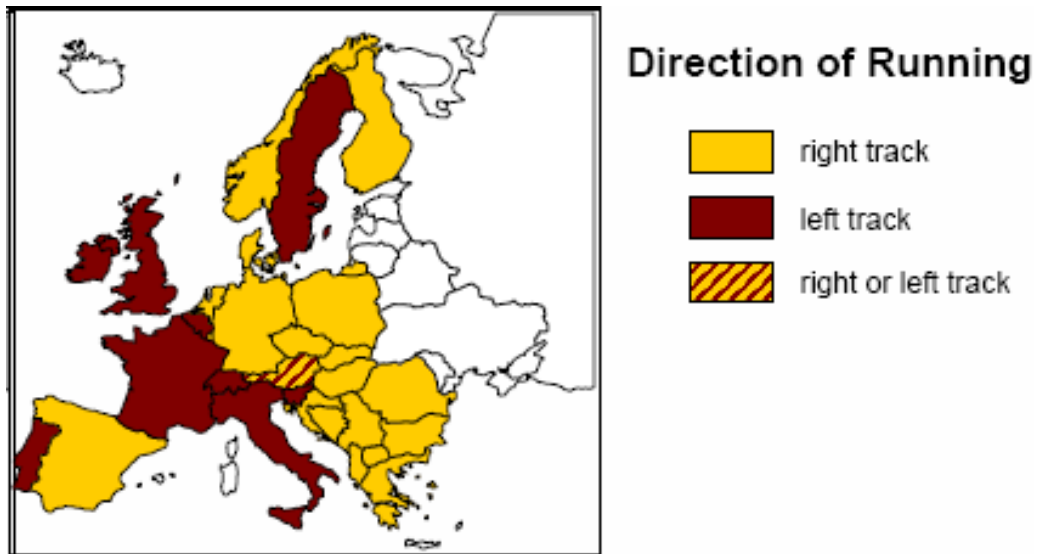

4.1.5 Different safety systems

Each country has its own safety systems for example ASFA in Spain, PZB in Germany, in France KVB, Netherlands ATBL_NL...

At the moment, a locomotive that operates in more than one country should have mounted the safety system of each country. The problem is solved but it means an extra cost for the operator in the purchasing price of the locomotive.

With the incorporation of ERTMS in all countries, at least in the main corridors, the Governments try to unify and use the same safety system. See more details in point 3.2.

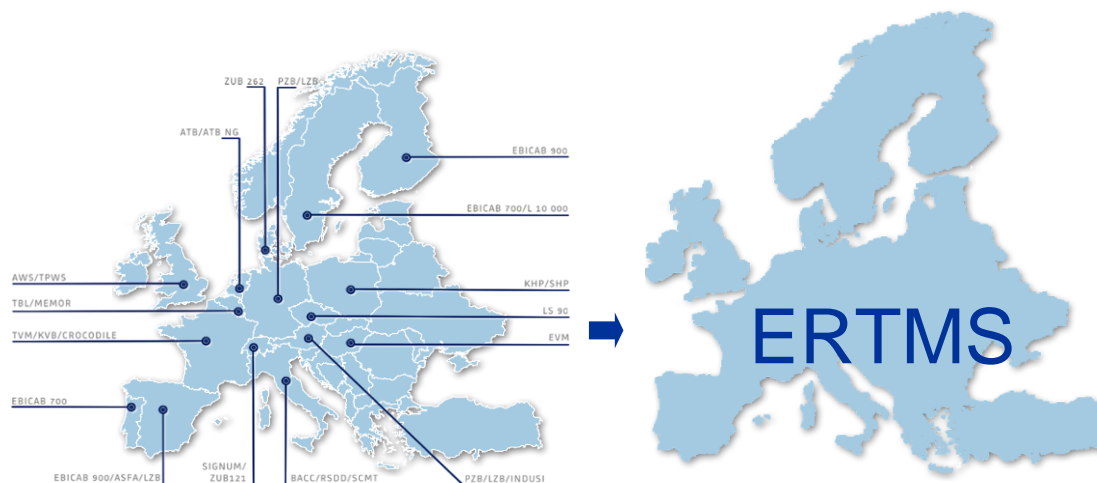

Figure 9

4.1.6 Different radio frequency and radio system

Also the radio frequency reserved for radio communications of railways is different in each country.

This interoperability barrier should be solved to operate trains with more than one locomotive along the train. The communications between locomotives, when one is in the head and the other/s in the middle or at the end of the train, should be by radio or by wire-connection. More details in “point 5.4. Multiple traction”,

All countries should reserve the same frequency range for railways communications or at least, it should be chosen some frequencies for this purpose.

With the implementation of ERTMS, the radio system for European railways will be GSM-R (more details in point 3.2: ERTMS)



4.2 ERTMS

Introduction

The European Railway Traffic Management System (ERTMS) is a major industrial project developed by six UNIFE members – Alstom Transport, Ansaldo STS, Bombardier Transportation, Invensys Rail Group, Siemens Mobility and Thales – in close cooperation with the European Union, railway stakeholders and the GSM-R industry.

ERTMS has two basic components:

- ETCS, the European Train Control System, is an automatic train protection system (ATP) to replace the existing national ATP-systems;
- GSM-R, a radio system for providing voice and data communication between the track and the train, based on standard GSM using frequencies specifically reserved for rail application with certain specific and advanced functions.

ERTMS aims at replacing the different national train control and command systems in Europe. The deployment of ERTMS will enable the creation of a seamless European railway system and increase European railway's competitiveness so what it makes border-crossing easier and remedy the fragmentary nature of the railway market, it increases both freight and passenger capacity, it reduces maintenance costs and it ensures maximum safety.

Why does Europe need ERTMS?

Currently there are more than 20 train control systems across the European Union. Each train used by a national rail company has to be equipped with at least one system but sometimes more, just to be able to run safely within that one country,

Each system is stand-alone and non-interoperable, and therefore requires extensive integration, engineering effort, raising total delivery costs for cross-border traffic. This restricts competition and hampers the competitiveness of the European rail sector vis-à-vis road transport by creating technical barriers to international journeys. For instance, the Thalys train sets running between Paris-Brussels-Cologne and Amsterdam have to be equipped with 7 different types of train control systems, which brings considerable costs.

A unique train control system for Europe and beyond

As a unique European train control system, ERTMS is designed to gradually replace the existing incompatible systems throughout Europe. This will bring considerable benefits to the railway sector as it will boost international freight and passenger transport.

In addition, ERTMS is arguably the most performant train control system in the world and brings significant advantages in terms of maintenance costs savings, safety, reliability, punctuality and traffic capacity. This explains why ERTMS is increasingly successful outside Europe, and is becoming the train control system of choice for countries such as China, India, Taiwan, South Korea and Saudi Arabia.

By making the rail sector more competitive, ERTMS helps to level the playing field with road transport and ultimately provides significant environmental gains.

ERTMS is as a result of the union between ETCS +GSM-R where ETCS is the new control-command system and GSM-R is the new radio system for voice and data communication. Together, they form ERTMS.

How does it work?

Thanks to ERTMS, trains can receive traffic management information (authorized speed, signals/points, safety distances between trains etc.) from the track, enabling it to calculate its maximum authorized speed continuously. A continuous stream of data informs the driver of line-specific data and signals status on the route ahead, allowing the train to reach its maximum or optimal speed but still maintaining a safe braking distance factor. This information is transmitted by standardized beacons –*eurobalises*–installed along the rails. FERRMED Locomotive uses ERTMS level 2 that there’s a continuous dialogue with the movement authority that’s communicated directly from a Radio Block Centre (RBC) to the onboard unit using GSM-R. In this way, the driver remains in uninterrupted contact with the control centers. Traditional track-based signals are no longer necessary.

Whilst enabling greatly reduced maintenance costs through the removal of lineside signals, ERTMS Level 2 also presents the possibility for substantial line capacity increase by enabling higher operational speeds and offering reduced headways: more capacity means more trains moving, this more benefits.

Also, there are more main benefits like much more interoperability, highest levels of safety, low installation and maintenance costs.

Here two pictures to show ERTMS level 2.

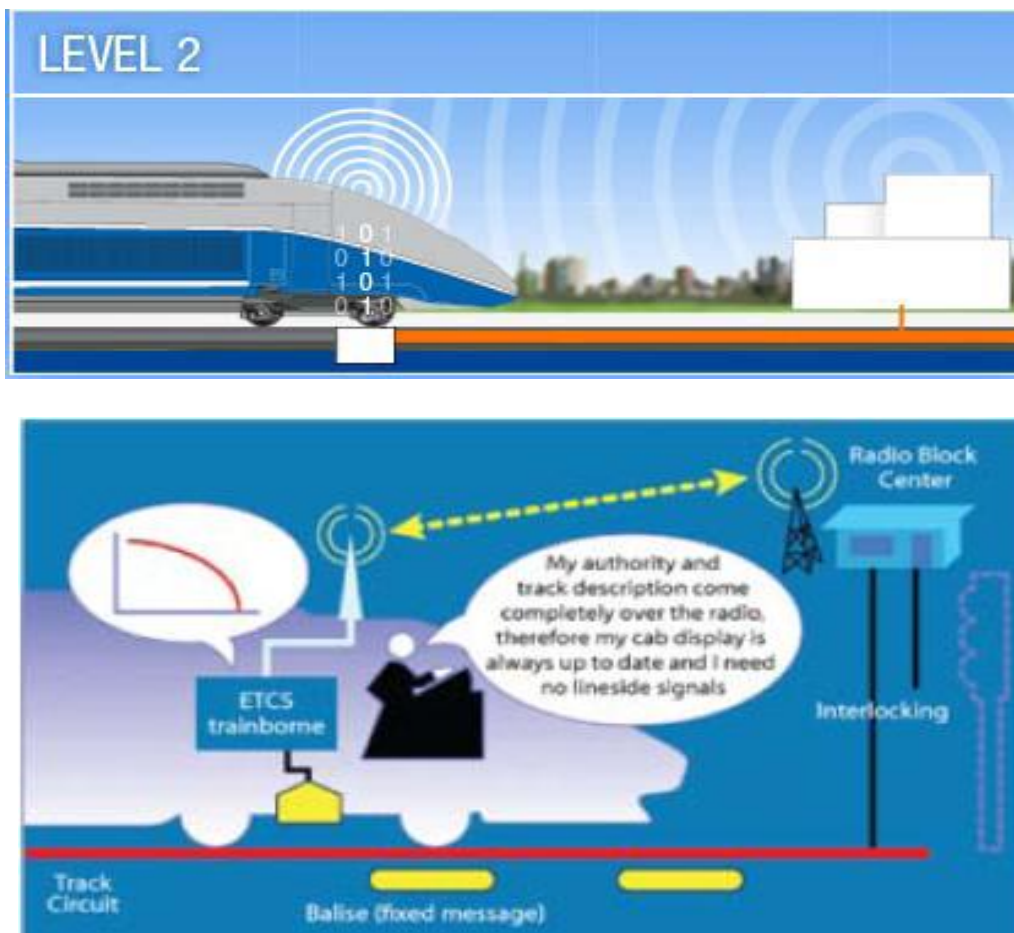
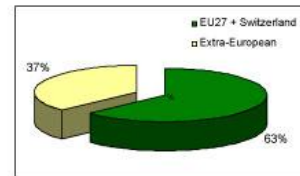
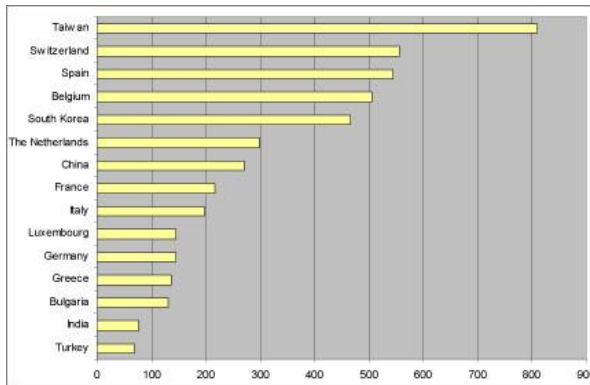

Figure 10. Source Internet
For more information, visit http://www.ertms.com/images2007/level2_video.mpg

State of art of ERTMS

Are our fleets adapted to ERTMS? How many trains are? Which countries are more adapted to that system? At the next information table are answer these questions

Statistics show that EU countries are gradually installing ERTMS on some of their train lines, countries outside Europe are also starting to embrace ERTMS as their train control system of choice. This is explained by the numerous benefits brought by ERTMS on top of interoperability. You can access the full list of ERTMS projects worldwide by visiting the projects part of the website.



Are the countries investing on ERTMS system?

ERTMS Investments in Europe (EU27+ Switzerland)

	Vehicles	Onboard Units	Route length	Track length
Austria	13	13	380	760
Belgium	506	506	416	496
Bulgaria	130	130	600	1100
Czech Republic	12	21	22	44
France	217	503	440	880
France/Spain	0	0	45	90
Germany	146	156	470	940
Greece	136	206	717,4	1269,4
Hungary	23	46	190	343
Italy	198	308	667	1230
Luxemburg	146	146	275	450
Netherlands	298	317	235	530
Romania	0	0	411	822
Slovakia	0	0	53	106
Spain	545	756	2089,6	4160
Switzerland	556	629	177,6	332
Sweden	1	221	3028	3178
United Kingdom	17	34	217	217
Total EU27 Switzerland	2944	3992	10433,6	16947,4

Countries are investing gradually in that project as well in the infrastructure as in the on-board equipment.

Some countries invest only in new vehicles equipped with this system like Austria and other overhaul the current fleet equipping vehicles and locomotives with onboard ERTMS systems, which is the case of Spain and France.



4.3 Cross-Acceptance

Currently, the second problem to cross Europe with the same train is that the rolling stock should be homologated in each country where it will operate.

Normally, countries recognize the certification of freight wagons, that is, if a country certifies a freight wagon type, other countries recognize also this certification and wagons of this type can run on them. There are some exceptions like Spain due to the different track gauge

Anyway, homologation of locomotives is still a big problem. Manufacturers should repeat same tests and documentation in each country where they want to sell the locomotives. For manufacturers that means a huge cost in money and time and besides, this cost is not easy forecasted in advanced.

On December 13th 2006, the European Commission adopted a series of measures to support the revitalization of the railway sector by removing obstacles to the circulation of trains throughout the European rail network. The measures included a Communication on the simplification of certification of railway vehicles, a proposal to recast the existing Railway Interoperability Directives and to modify the Regulation establishing a European Railway Agency and the Railway Safety Directive.

Countries had also adopted measurements to facilitate the homologation of locomotives and the cross-border rail traffic by Cross-Acceptance agreements.

Cross-Acceptance is an intermediate step to the total European Interoperability. They are bilateral agreements between neighboring countries where they decide which issues and norms are similar in both countries and which not. Rolling stock already homologated in a country should not repeat the whole homologation process in the second one; the similar issues will be automatic accepted and only the differences should repeat the homologation tests. For example, Dynamic behavior tests according UIC518 / EN14363 must be repeated in France and in Germany due to different track conicity (1/40 in Germany and 1/20 in France). This item is not Cross-Acceptable.

Cross-Acceptance agreements facilitate homologation process and save costs and time to the manufacturers. As a consequence, cross-acceptance will be reduce the purchasing cost of the rolling stock and it will make more competitive the rail freight transport.

Germany has Cross-Acceptance agreements with all its neighboring countries.

France and Spain signed also a Cross Acceptance protocol at beginning 2010.

Cross Acceptance – The „Pillars“ creating the European „Web“



Figure 11

“FERRMED Locomotives” should be interoperable and homologated in all EU countries, so they should meet following requirements:

- Fulfil all applicable TSI, European Directives and country-specific norms
- Be able for track gauge 1435mm
- Diesel or electrical multi-tension at least until the whole network has the same voltage, 25kV
- Equipped with European Central Desk
- Be able for ERTMS Level 2: equipped with ETCS and GSM-R radio system



5 STATE-OF-THE-ART WORLDWIDE LOCOMOTIVES

Continent	Locomotive Name	Manufacturer	Type	Power (MW)	Nº of axles	Starting effort (kN)	Weight (T)	Axle load	Max. Speed (Kph)	Coupling type	Build date
Europe	Prima I*	Alstom	Electric	4,2	4	320	90	22,5	140	UIC-type	2001
Europe	Prima II*	Alstom	Electric	6,4(B)	4	320 (B)	88(B)	22.5	140 (B)	UICD-type	2009
Europe	EURO3000	Vossloh	DE	2,4	4	280	82	20,5	120	UIC-type	2005
Europe	EURO4000	Vossloh	DE	3,2	6	400	123	20,5	120	UIC-type-135t	2006
Europe	EUROLight	Vossloh	DE	2,8	4	300	79	19,75	120	UIC-type	2010
Europe	G2000BB	Vossloh	DH	2,24	4	283	87,3	21,8	120	UIC-type	2000
Europe	Eurosprinter ES64F4*	Siemens	Electric	6,4	4	300	87	21,75	140	UIC-type	2003
Europe	Eurorunner ER20	Siemens	DE	2	4	235	80?	20?	90/140	UIC-type	2004
Europe / Lithuania	Eurorunner ER20CF	Siemens	DE	2	6	450	135,7	22,6	120	SAE3	2007
Europe	Traxx F140MS*	Bombardier	Electric	5,6	4	300	85	21,25	140	UIC-type	2006
Europe	Traxx F140DE	Bombardier	DE	2,2	4	270	80?	20?	140	UIC-type	2006
Europe	Class 380 ČD	Skoda	Electric	6,4	4	274	-		200	UIC-type	
Europe	Class 66/ JT42CWR	EMD	DE	2,42/ 2,2Tractiv	6	409	126,9	21,1	120	UIC-type	1998
Europe	PowerHaul	GE	DE	2,75	6		129	21,5	120	UIC-type	2009
Europe	Maxima 40 CC	Voith	DH	3,6	6	408	135	22,5	120	UIC-type	2006
Europe / Poland	E6ACT	ZNLE	Electric	5	6		116	19,3	140	UIC-type	2009
Europe	Bitrac	CAF	Dual	4,4/3,6	6	445	135	22,5	120	UIC-type	2010

FERRMED FREIGHT LOCOMOTIVE CONCEPT STUDY



Continent	Locomotive Name	Manufacturer	Type	Power (MW)	Nº of axles	Starting effort (kN)	Weight (T)	Axle load	Max. Speed (Kph)	Coupling type	Build date
USA**	SDT70M-2	EMD	DE	3,2 MW (4.300THP)	6	725	177	29.5	112	Automatic	2007
USA**	SDT70ACe	EMD	DE		6	850	185	31	112	Automatic	2005
USA**	ES44DC	GE	DE	3,28 MW (4.400HP)	6	632	186	31	112,6	Automatic	
USA**	ES44AC	GE	DE		6	880	188	31,3	120	Automatic	2003
Australia	SD70ACe/lc or GT46 ACe	EMD	DE	3,2	6	600	134	22,7	130	Automatic	2005
Australia	ES44ACi or AC6000CW	GE	DE	4,6	6		192	32	120	Automatic	
Australia	Class 7100	Siemens	Electric	4	6		132	22	80	Automatic	
China	HXD1	Siemens/Zhuzh	Electric	9,6	8	760	200	25	120	Automatic	2006
	HXD2	Alstom/Datong									
China	HXD3	Dalian/Toshiba	Electric	7,2	6	570	150	25	120	Automatic	2006
China	HXD1B	Siemens / Zhuzhou	Electric	9,6	6		150	25	120	Automatic	2009
China	HXD2B /Prima	Alstom/Datong	Electric	9,6	6	580	150	25	120	Automatic	2010
China	HXD3B	Bombardier/ Dalian	Electric	9,6	6	580	150	25	120	Automatic	2010
China	HXN3 / JT56ACe	EMD/Dalian	DE	4,5 MW (6000HP)	6	620	150	25	120	Automatic	2008
China	ES59ACi / HXN5	GE/Qishuyan	DE	4,660 MW (6250HP)	6	620	150	25	120	Automatic	2008
India	GT46MAC/ WDG-4	EMD/DLW	DE	3MW (4000HP)	6	540	126	21	160	UIC/ Automatic	2001
India	WAG-9H	ABB/CLW	Electric		4,5 MW (6000HP)	6	510	135	22,5	100	UIC/ Automatic
Japan	EH200	Toshiba	Electric	4,52	4+4	271,8	134,4	16,8	110	UIC/ Automatic	2001
Russia	Tep70	Kolomensky Zavod	DE	2,9	6	288	135	21,8	160	SA-3	1973
South Africa	GT206CU-3/Class 39-200	EMD	DE	2,4	6	350 KN	126	21	140	Automatic (knuckle coupler)	

FERMED FREIGHT LOCOMOTIVE CONCEPT STUDY



Notes:

* It has been taken into account only the multi-system electric locomotives of Alstom, Siemens and Bombardier because they are the newest but there are also other models of electric locomotives which voltage depend on the country where are running.

** GE and EMD developed for USA DE locomotives with 6.000HP but in both cases these locomotives gave lots of problems and there are only few in operation. So, for this study it has been taken into account only the newest locomotives of GE and EMD with 4,400 HP and 4,300 HP respectively both with traction DC and AC.

Conclusions of the table

The tables summarize the state-of-the-art freight locomotives that operate in Europe and in other countries to compare them and to see what it is necessary for long and heavy trains and what can be used in Europe. ,.

How is the European's Locomotive fleet today? What about the other and most important countries on railway freight transport? What should be improved? Could we take the model of other countries for Europe? The questions should be answer after this analysis about our markets

○ **USA:**

In USA, the allowed axle-load is higher than 30t/axles, the locomotives weight much more than in other countries so they have high adhesion and starting tractive effort (around 700 kN – 850kN). Therefore, these locomotives can haul higher loads than in other countries.

Rail infrastructure in USA is used mostly by transporting goods and it is not electrified. They used Co-Co diesel locomotives of around 4.000 – 5.000 HP and to get more power use multiple traction (2 or more locomotives along the train).

They use also automatic coupling that have double resistance that European ones.

All these factor: infrastructure, higher axle-load, automatic coupling, multiple traction... allow long and heavy trains like FERRMED proposes. But most of these factors are not possible at the moment in Europe due to infrastructure constrains.

○ **CHINA:**

The newest Chinese locomotives do not weight so much like American ones although achieve 25 t/axles (about 10% more than in Europe) .They have 6 axles, tractive effort around 600 KN (almost double than European locomotives), automatic coupling and are powerful.

In China, both kinds of traction, the electric traction and the diesel one are used.

Trains achieve here also 2.500m.

○ **AUSTRALIA, INDIA, SOUTH AFRICA:**

In Australia, India and South Africa trains are normally very long (around 2 km) but axle loads are similar to European ones. The difference with Europe is that they used Co-Co locomotives with high starting tractive effort and automatic coupling that allow multiple traction.

FERRMED FREIGHT LOCOMOTIVE CONCEPT STUDY



- **EUROPE:**

In Europe, there are electric and diesel locomotives and they can have 4 or 6 axles.

The power is between 2 and 6 MW and tractive effort is around 300kN for Bo-Bo locomotives and 400kN for Co-Co locomotives.

The axle load is restricted to 22,5 t/axle and automatic coupling is not used. Screw coupling, with less resistance of automatic ones, allows just 2 locomotives in the head of the train.

All these rolling-stock factors together with the network restrictions described before make European freight trains "short and light"

In following chapters it will be described how future European locomotives should be to haul trains of 1.500m and 3.600 t ÷ 5.000t.



6 REQUIRED STARTING TRACTIVE EFFORT AND POWER TO HAUL “FERRMED TRAINS”

6.1 Why trains of 3.600t up to 5.000t?

FERRMED proposed trains of 1.500m to have the possibility to joint two trains of 750m or three trains of 500m that coming from feeder lines in a unique train that can run on main corridor.

6.1.1 Intermodal train of 1.500 m

There are many different freight wagons for container transport, for example, Lgnss45´, Sgnss 60´, Sggrss 80´, Sggmrss 90´, Sggmrss 104´. The most used in Europe is the bogie wagon of 60´ but due to the increase of maritime containers of 40´ and 45´, the wagon of 80´ and 90´ have a greater potential to be used in the future.

	LMPW 80´ FERRMED	Lgnss45´	Sgnss 60´	Sggrss 80´	Sggmrss 90´
Aprox. Length	26 m	14 m	20 m	26,4 m	29,6 m
Aprox. Tare weight	24 t	12 t	20 t	26 t	29 t
Max. weight	100 t	45 t	90 t	135 t	135 t
Load capacity	76 t	33 t	70 t	109 t	106 t
Load capacity	4 TEU	2 TEU	3 TEU	4 TEU	4 TEU
Aprox. tare of 20´ container	2 t	2 t	2 t	2 t	2 t
Axle-load	25 t/axle	22,5 t/axle	22,5 t/axle	22,5 t/axle	22,5 t
Number of wagons	55	103	73	55	49
Number of TEU (20´ container)	220	206	219	220	196
Maximal gross weight	5.500 t	4.635 t	6.570 t	7.425 t	6.615 t
maximal payload	3.740 t	2.987 t	4.672 t	5.555 t	4.802 t
Length of train without locos	1.425 m	1.442 m	1.460 m	1.452 m	1450,4 m

It has been also considered the FERRMED long multi-purpose wagon of 80´ (LMPW) described in the study “FERRMED Wagon Concept”.

In a train of 1.500m fit 55 wagons of 80´ or 73 of 60´, that is, 220 TEUS.

Normally wagons and also the containers are not loaded at maximum. Besides, it is very usual to transport empty containers and empty wagons and mixed in the same trains full wagons with empty ones.

“FERRMED trains” (3.600t -5.000t) can be calculated considering a ratio load superior to 50%.



6.1.2 Bulk train of 1.500 m

Shorter wagons are used to transport heavy cargo. Normally the length of these wagons is around 14m or around 18,5m depending of the use.

“FERRMED Wagon Concept” develops two kinds of platform wagons for heavy load and 25 t/axle

	FERRMED				
	Smms-1	Smms-2	Sgmmns-w	HCW-1	HCW-2
Aprox. Length	13,86 m	18,53 m	13,9 m	13,7 m	17,2 m
Aprox.Tare weight	20,6 t	22,2 t	18,2 t	17 t	19 t
Max.weight	79,6 t	80,2 t	100 t	100 t	100 t
Load capacity	59 t	58 t	81,8 t	83 t	81 t
Axle-load	20 t	20 t	25 t	25 t	25 t
Number of wagons	105	80	105	106	85
Maximal gross weight	8.358 t	6.416 t	10.500 t	10.600 t	8.500 t
maximal payload	6.195 t	4.640 t	8.589 t	8.798 t	6.885 t
Length of train without locos	1455,3 m	1482,4 m	1459,5 m	1452,2 m	1462 m
Number of wagons	50	38	50	50	40
Maximal gross weight	3.980 t	3.048 t	5.000 t	5.000 t	4.000 t
maximal payload	2.950 t	2.204 t	4.090 t	4.150 t	3.240 t
Length of train without locos	693 m	704,14 m	695 m	685 m	688 m

Normally bulk trains are loaded to their maximum capacity, that is, the load ratio is around 100%. As we can see in the table, a bulk train of 1.500m can have a gross weight of around 10.000t.

It seems more efficient because of traction and brake reasons to limit to 750m the trains with heavy cargo, so the maximum gross weight is between 3.000 and 5.000t.

6.2 Maximum admissible trains gross weight

Train gross weight includes the tare-weight of the wagons and the payload but it does not include the weight of the locomotive. It is also called “load of the trains”.

It is calculated as the minimum between the maximum admissible train gross weight in the start and the maximum admissible train gross weight during running.

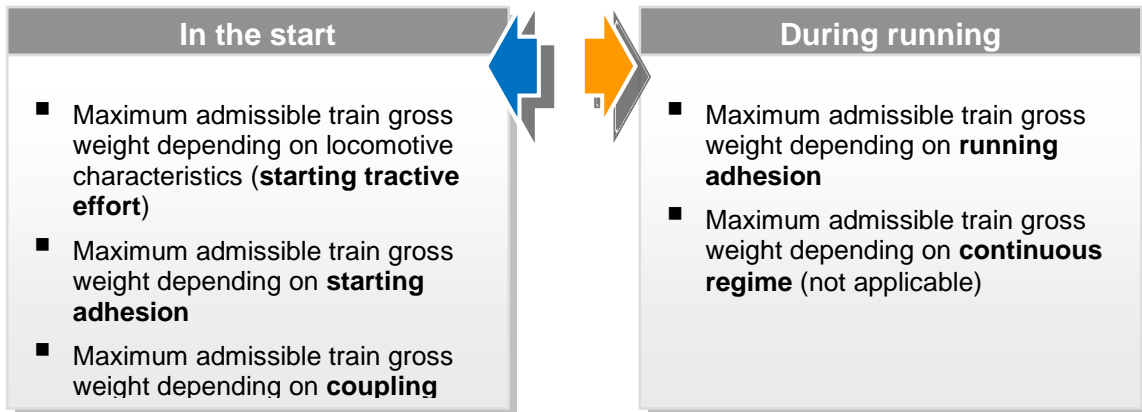

6.2.1 Maximum admissible train gross weight in the start

The maximum admissible train gross weight that a locomotive can start is defined by the maximum tractive effort at wheel rim of the locomotive during the start and that can be limited by the own characteristics of the locomotive or by the starting adhesion.

The effort in the coupling limits also the maximum admissible load of the train.

6.2.1.1 Maximum train gross weight that can be started depending on starting tractive effort

Maximum admissible train gross weight depending on the starting tractive effort of the locomotive is calculated by:

$$Q \leq [(F_s / 9,8 * 1000) / (r_s + i)] - L$$

Where:

- Q is the load or gross weight of the train in tons
- F_s is the starting tractive effort in kN
- r_s is the starting resistance of the train and according to Spanish norm NT – GGC -6 is 7 daN/t for slopes lower that 15 ‰ but for freight trains r_s is 4 daN/t due to the resistance due to acceleration is not considered. In this study, $r_s = 4$ daN/t
- i is the slope or gradient.
- L is the weight of the locomotive in tons.



Following table will compare in different gradient situation which is the maximum admissible train gross weight that can be started with current locomotives.

Three examples of locomotives has been taken into account: an American locomotive of GE (ES44AC), a generic European Co-Co locomotive and a generic European Bo-Bo locomotive. Co-Co locomotives have 6 motorized axles and therefore, a higher starting tractive effort. In Europe, these locomotives weigh between 120 and 135 t and their starting tractive effort is around 400 kN. Bo-Bo locomotives have 4 motorized axles, in Europe weigh 80 t - 90 t and have a starting tractive effort of 275 kN -300kN.

	Loco Weight	Starting tractive effort	Slopes	Maximum admissible gross weight
USA: GE ES44AC	188 t	880 kN	0‰	22.261 t
Europe: Co-Co	125 t	400 kN	0‰	10.079 t
Europe: Bo-Bo	85 t	300 kN	0‰	7.568 t
USA: GE ES44AC	188 t	880 kN	4‰	11.036,5 t
Europe: Co-Co	125 t	400 kN	4‰	4.977 t
Europe: Bo-Bo	85 t	300kN	4‰	3.741,5 t
USA: GE ES44AC	188 t	880 kN	12‰	5.424 t
Europe: Co-Co	125 t	400 kN	12‰	2.426 t
Europe: Bo-Bo	85 t	300 kN	12‰	1.828 t
USA: GE ES44AC	188 t	880 kN	18‰	3.894 t
Europe: Co-Co	125 t	400 kN	18‰	1.730 t
Europe: Bo-Bo	85 t	300 kN	18‰	1.306 t

Conclusions:

1. Higher starting tractive effort → possibility of heavier trains
2. American locomotives, with an axle-load higher than 30 t/axle, have a higher starting tractive effort that European locomotives with an axle-load between 20 and 22,5 t/axle. Hence, American locomotives can start heavier trains that European ones.
3. The capacity of starting heavier trains decreases with the slopes. Therefore, rail freight lines should have the possible lowest gradients in each point. The maximum admissible load of the train will be conditioned by the capacity of the locomotive of starting in the inclined stretch of the rail line.
4. At least 2 Co-Co locomotives or 3 Bo-Bo locomotives are required in Europe to start the "FERRMED trains" of 3.600 ÷ 5.000t in lines with a gradient of 12‰. The number of locomotives per train also depends on the nominal power available to reach the required nominal speed.
5. In some rail lines with small slopes, 1 Co-Co or 2 Bo-Bo locomotives will be enough to start "FERRMED trains".

FERRMED FREIGHT LOCOMOTIVE CONCEPT STUDY

6.2.1.2 Maximum admissible train gross weight depending on the starting adhesion

During the starting, the maximum tractive effort at wheel rim without slipping is:

$$F_{\mu 0} = \mu_0 * L_a$$

Where,

- $F_{\mu 0}$ is the maximum tractive effort depending of the starting adhesion
- μ_0 is the starting adhesion
- L_a is the adherent weight of the locomotive, if all axles are motorized; the adherent weight is the total weight of the locomotive.

The adherent weight of the locomotive is the weight that support all motorized axles and can be increased by increasing the number of axles or the axle-load.

And the maximum train gross weight is calculated by:

$$Q \leq [(F_{\mu 0} * 1000) / (r_s + i)] - L$$

Where:

- Q is the load or gross weight of the train
- r_s is the starting resistance of the train. In this study $r_s = 4 \text{ daN/t}$
- i is the slope or gradient.
- L is the weight of the locomotive

In old locomotives with an electromechanical adhesion control system, μ_0 was not higher than 20% but with the current systems μ_0 can achieve 33% or even 40% in some countries. See more details on paragraph 7.2

μ_0	Loco Weight	Slope	Maximum train gross weight
33%	125t	0 ‰	10.188 t
26%	125t	0 ‰	8.000 t
33%	85t	0 ‰	6.928 t
26%	85t	0 ‰	5.440 t
33%	125t	4 ‰	5.031 t
26%	125t	4 ‰	3.938 t



33%	85t	4 ‰	3.421 t
26%	85t	4 ‰	2.678 t
33%	125t	12 ‰	2453 t
26%	125t	12 ‰	1.906 t
33%	85t	12 ‰	1.668 t
26%	85t	12 ‰	1.296 t
33%	125 t	18 ‰	1.750 t
26%	125 t	18 ‰	1.352 t
33%	85 t	18 ‰	1.190 t
26%	85 t	18 ‰	920 t

Conclusions:

- 1 Load of the train can be increased by increasing the adhesion coefficient or the adherent weight of the locomotive, that is, the number of axles or the axle-load.
- 2 Locomotive weight is limited by the admissible axle-load that in Europe is 22,5 t/axles or even 20t/axles in some secondary lines.
- 3 One Co-Co locomotive can start and haul just 2.000 t up to 2.500t in slopes of 12mm/m. In the case of Bo-Bo locomotives this load is even lower, between 1.300 t and 1.700 t depending on the adhesion coefficient.
- 4 Using 2 or more locomotives, the number of motorized axles grows and therefore also the adherent weight. So, we will be able to transport more tons in high slopes.
- 5 **At least 12 motorized axles are required in Europe to start the “FERRMED trains” of 3.600 - 5.000 t in lines with a gradient of 12‰, that is, at least 2 Co-Co locomotives or 3 Bo-Bo locomotives**
- 6 Adhesion coefficient can be increased with new technologies (see point 7.2) but also the norms accepted by the Infrastructure managers should be updated.

6.2.1.3 Maximum train gross weight that can be started with current locomotives depending on the coupling type that they have.

The load hauled by the locomotive, that is, the train gross weight, can not exceed the limit effort of the coupling resistance.

For couplings of 85 t (normal type in Europe), the maximum tractive effort is of 36 t in the coupling, that supposes a security coefficient of 2,4.

In Europe, it is also used a reinforced coupling of 135 t, applying the same security coefficient, the maximum tractive effort in coupling is 57 t. There are not more resistant couplings in Europe

The maximum load in the start offering by each coupling type is:

$$\boxed{Q \leq (36 * 1000) / (rs + i)} \quad \text{Or} \quad \boxed{Q \leq (57 * 1000) / (rs + i)}$$

FERRMED FREIGHT LOCOMOTIVE CONCEPT STUDY

Where:

- Q is the load or gross weight of the train
- r_s is the starting resistance of the train. In this study $r_s = 4 \text{ daN/t}$
- i is the slope or gradient.

Coupling type	Slope	Maximum train gross weight
UIC coupling of 135 t	0 ‰	14.294 t
UIC coupling of 85 t	0 ‰	9.000 t
UIC coupling of 135 t	4 ‰	7.147 t
UIC coupling of 85 t	4 ‰	4.500 t
UIC coupling of 135 t	12 ‰	3.574 t
UIC coupling of 85 t	12 ‰	2.250 t
UIC coupling of 135 t	18 ‰	2.599 t
UIC coupling of 85 t	18 ‰	1.636 t

Conclusions:

1. With the current coupling used in Europe of 85 t is not possible to haul trains of 5.000t without breaking the coupling.
2. At least, reinforced UIC coupling of 135 t should be used in locomotives and in wagons.
3. With existing European screw couplings, 3.500t are the maximum load without breaking the coupling during the starting in a slope of 12 ‰.
4. Better option should be **to change current screw couplings for automatic ones** that allow more load (some of them can duplicate the load of the reinforced screw coupling) but also they have other advantages respect the screw couplings like: more safety, more speed in train formations, possibility of longer trains...See point 7.3 for more details.

6.2.2 Maximum train gross weight during running

Other limitation of the maximum train gross weight is given by:

- a) Adhesion during running
- b) Continuous regime

6.2.2.1 Adhesion during running

Adhesion is inversely proportional to the speed.



There are different ways to calculate the adhesion and each administration use their own formula:

- RENFE for example uses: $\mu = \mu_0 (0.2115 + 33/(V+42))$
- Müller formula is common used: $\mu = \mu_0 / (1+0,01 V)$
- Curtius-kniffer formula: $\mu = 1,161 + 7,5 (44+V)$

During running, the maximum tractive effort at wheel rim without slipping is:

$$F_{\mu} = \mu * L_a$$

Where:

- F_{μ} is the maximum tractive effort depending of the starting adhesion
- μ is the adhesion
- L_a is the adherent weight of the locomotive, if all axles are motorized, the adherent weight is the total weight of the locomotive

And the maximum train gross weight is calculated by:

$$Q \leq [(F * 1.000) - (EL+L*(i+1)) / (r + i+1)]$$

Where:

- Q is the load or gross weight of the train
- F is the intersection between the adhesion curve and the characteristic curve of the locomotive
- i is the slope or gradient.
- L is the weight of the locomotive
- EL is the resistance of the locomotive
- r is the resistance of the train

The running resistance of locomotives and train can be calculated in different ways depending on the Administration.

RENFE:

$$EL = 0,65*L+13*n+0,01*L*V+0,03V^2 \text{ (daN)}$$

$$r = 2+ V^2 /1.600 \text{ (daN/t) for freight trains}$$

$$r = 2+ V^2 /4.000 \text{ (daN/t) for passenger trains}$$

SNCF:

$$EL =1,25 + 0,01V + 0,00025 V^2 \text{ (kg/t) for Co-Co locomotive}$$

$$r = 1,5+ V^2 /1.600 \text{ (kg/t) for diverse freight trains}$$

$$r = 1,5+ V^2 /4.000 \text{ (kg/t) for specialized (homogeneous) freight trains}$$



6.2.2.2 Continuous regime

This concept defines the maximum speed and maximum tractive effort at the maximum power when the environmental temperature is also very high. (The probability that all these factors coincide in the time is almost zero).

Besides, new locomotives regulate themselves reducing the speed and tractive effort if the external conditions are unfavorable.

Actually continuous regime is not considered as limitation of train-load.



6.3 Starting tractive effort required to haul FERRMED trains

At this point, we will make the inverse calculation. The load is given and we will calculate the required starting tractive effort to start the train in different slopes.

As the table shows, the difference between a Co-Co and a Bo-Bo locomotive is very small. Co-Co locomotives need few kN more than Bo-Bo locomotives because of the locomotive weight.

Load	Slope	Starting tractive effort in Co-Co locomotives (125t)	Starting tractive effort in Bo-Bo locomotives (85t)
3.600 t	0 ‰	146 kN	144,5 kN
3.600 t	4 ‰	292 kN	289 kN
3.600 t	12 ‰	584 kN	578 kN
3.600 t	18 ‰	803 kN	794,5 kN
5.000 t	0 ‰	201 kN	199 kN
5.000 t	4 ‰	402 kN	399 kN
5.000t	12 ‰	804 kN	797 kN
5.000t	18 ‰	1.105 kN	1.096 kN

Conclusions:

1. To start “FERRMED trains” in slopes of 12 ‰, it is necessary starting tractive efforts of 600 kN up to 800 kN.
2. As it has been seen before, European locomotives have starting tractive effort of 300 kN ÷ 400 kN. So, it will be required **at least two locomotives** to start such trains in high slopes.
3. One locomotive will be able to start “FERRMED trains” just in cases where the slopes are small, lower than 4 ‰.



6.4 Power required to haul FERRMED trains at a defined speed

As it has been seen before, power does not influence the capacity of a locomotive to haul heavier trains as the current European ones.

But power is required to run the locomotive with an expected speed. Following table will show the required power at wheel rim to haul "FERRMED trains" with different speeds and slopes.

Train gross weight	Slope	Speed	Power at wheel rim
3.600 t	0 ‰	40 km/h	1.178 kW
		60 km/h	2.075 kW
		100 km/h	5.093 kW
		120 km/h	7.215 kW
	4 ‰	40 km/h	2.800 kW
		60 km/h	4.509 kW
		100 km/h	9.149 kW
		120 km/h	12.324 kW
	12 ‰	40 km/h	6.045 kW
		60 km/h	9.376 kW
		100 km/h	17.261 kW
		120 km/h	22.058 kW
	18 ‰	40 km/h	8.479 kW
		60 km/h	13.027 kW
		100 km/h	23.346 kW
		120 km/h	29.360 kW

Calculations were made with a locomotive of 6 axles and 125 t (the difference between Co-Co and Bo-Bo Locomotives have small influence in the required power). The formulas used for the locomotive and train resistance are:

$$EL = 0,65 \cdot L + 13 \cdot n + 0,01 \cdot L \cdot V + 0,03V^2 \text{ (daN)}$$

$$r = 1,5 + V^2 / 4.000 \text{ (kg/t)}$$

The calculated power is the power required at wheel rim, that means, that the diesel engine or pantograph should provide even more kW for auxiliary equipment and for energy losses in the different locomotive components.



Train gross weight	Slope	Speed	Power at wheel rim
5.000 t	0 ‰	40 km/h	1.609 KW
		60 km/h	2.853 KW
		100 km/h	6.999 KW
		120 km/h	10.246 KW
	4 ‰	40 km/h	3.824 KW
		60 km/h	6.201 KW
		100 km/h	12.579 KW
		120 km/h	16.943 KW
	12 ‰	40 km/h	8.326 KW
		60 km/h	12.898 KW
		100 km/h	23.740 KW
		120 km/h	30.336 KW
	18 ‰	40 km/h	11.666 KW
		60 km/h	17.920 KW
		100 km/h	32.111 KW
		120 km/h	40.381 KW

Conclusions:

1. Required power increases a lot with the speed and with the slopes.
2. To save energy it is necessary to have a commitment between the speed, the load and the schedule. To run at 120 km/h in high slopes that normally are very short (1 or 2 km) does not save time and has a high energy cost. In freight transport, normally it is not important the pick-speed, it is more important the average speed and arrives on time to the destination.
3. Heavy trains can achieve high speed only on flat or with a very small slope. If the slope increases, the velocity should decrease.
4. To haul "FERRMED trains" (3.600t ÷ 5.000t) maximum speed can not be 120km/h, maximum speed will be below 100km/h depending on the slope.
5. **Between 7.000 kW and 10.000kW are required to haul "FERRMED trains" in an acceptable speed.** For cost reasons (acquisition, maintenance, operating costs), it is better to have only one powerful locomotive but as we have seen before, to start in high slopes such trains at least two locomotives are required, so, FERRMED proposes as the best option to have **locomotives of 3.500kW – 5.000 kW working in multiple.**



6.5 General conclusions:

1. The **maximum train gross weight** or load that a locomotive can haul is given as the minimum between:
 - a. The load that the coupling hold without breaking,
 - b. The load that can be started due to the starting adhesion
 - c. The load that can be started due to locomotive design (starting tractive effort)
 - d. The load that can be hauled without sliding (adhesion during running)
2. **More power does not mean more load.** More powerful locomotive allows operations at higher speed and acceleration, but there are other parameters that define if a load can be hauled or not and if this train can start or not. These parameters are:
 - Gradient of the slopes
 - Type of coupling
 - Adhesion
 - Starting tractive effort of the locomotive
 - Adherent weight of the locomotives that depends of the number of motorized axles and of the axle load.
3. **Starting tractive effort** required to start and to haul “FERRMED trains” (length of 1500m and 3600 ÷ 5000t) in slopes of 12‰ are between **600kN and 800kN** depending on the total tons transported. That is double than current European locomotives have (300kN have Bo-Bo locomotives, 400kN have Co-Co locomotives) → **more than 1 locomotive** it is required.
4. **Adherent weight** of the locomotives increases with the number of motorized axles of the locomotive and with the axle-load. Under European infrastructure constrains (maximum 22,5 t/axle), **12 motorized axles** are required to haul “FERRMED trains”, that means, 2 or more locomotives working in multiple traction.
5. Therefore, although in terms of operational costs, maintenance costs... it will be more competitive to operate “FERRMED Trains” with just a powerful locomotive; we will need at least 2 Co-Co locomotives or 3 Bo-Bo locomotives to start such trains of 3.600 t -5.000t in slopes of 12‰.
6. The total **power** required to haul “FERRMED trains” in an adequate speed will round 7.000 kW to 10.000 kW. But, it is enough that FERRMED Locomotive has between **3.500 kW and 5.000kW** due to they should work in multiple traction. Anyway, more powerful locomotives have advantages respect speed and acceleration.
7. Couplings with higher resistance as the current screw coupling are also required. **Automatic coupling** is the best option in terms of safety but also to allow longer trains than current European ones.
8. Limitations of **adhesion** by the Infrastructure Administrations should be also revised and updated. Current and future locomotives can achieve better adhesion coefficients than former ones, thanks to new technologies.
9. To **save energy** it is necessary a commitment between the speed, the load and the schedule. To run at 120 km/h in high slopes that normally are very short (1 or 2 km) does not save time and has a high energy cost.



7 TECHNICAL PARAMETERS TO HAUL HEAVIER AND LONGER TRAINS

7.1 Power supply

7.1.1 Electric Locomotives

7.1.1.1 Pantograph

The pantograph is the system that permits the electrical alimentation of the train by the catenary contact wire.

It is composed of these five main elements:

- **The rigid frame.**

Composed of welded steel profiles. It supports the articulated system and the equilibration system. It has three points for the fixation over the synthetic insulation foots insulators which connect it to the roof of the train. One point permits the HV electrical connection. An eventual spark would be collected by a spark gap settled between the train roof and the pantograph.

- **The articulated system.**

It is composed of:

- A lower arm, of big diameter and T form. It is articulated over the rigid frame and transmits the torque from the equilibration system.
- A simple effect shock absorber between the lower arm and the rigid frame.
- A lower connecting rod, of inferior diameter and made of conductive material. It is articulated over a fixed point of the rigid frame.
- A profiled upper arm, made of conductive material, and articulated over the lower arm and the lower connecting rod.
- An anti swing shaft articulated over the upper arm.
- An anti swing rod articulated on one of its ends over the lower arm, and the other extremity over the anti swing shaft.

The anti swing shaft and the anti swing rod keep the panhead horizontal on the entire catenary contact area.

All the articulations use bearings without maintenance.

The pantograph extension is mechanically limited and the maximum extension can be adjusted depending on the network configuration. The limiting device consists of a retractable hook causing the block of extension of the pantograph. The extension shall be specified according to the network parameters.

- **The equilibration system.**

It equilibrates the articulated system and assures the contact force.

The equilibration is made thanks to a pneumatic cushion which creates a torque over the (lower) arm through a cam-traction wire system. On the one hand, it is rigidly fixed over the frame and on the other hand, it is suspended by a traction wire.



- **The bow:**

Its function consists in keeping the contact with the catenary in order to optimize the current collection quality. It has two contact strips, made of suitable material according to TSI Directive. A pneumatic emergency system immediately drops the pantograph if the carbon strips are damaged. If the air pressure in this circuit decreases rapidly, the pneumatic cushion is exhausted.

- **The electro pneumatic command system:**

This system keeps a constant pressure in the pneumatic cushion whatever the height of the catenary is. It permits the regulation of the rising and lowering speed of the pantograph. The pneumatic unit must be adjustable for all network configurations.

It is composed of:

- An electric valve, to control the rising of the pantograph.
- An air flow regulator system, to regulate the rising speed of the pantograph.
- Active Pressure control systems, to regulate the static forces and aerodynamic forces depending on the network, the loco configuration and eventually on the speed .
- An air flow regulator system, to regulate the lowering speed of the pantograph.
- Electronic/Electro Pneumatic pantograph control system shall be interfaced with the on board bus communication system.

Equipment for pantograph:

- *Panheads*: there are different configurations currently used in Europe:

		Type A	Type B	Type C	Type D
Dimensions	Norm	UIC 608	UIC 608	UIC 608	UIC 608
	Hauteur (mm)	300	300	300	340
	Width (mm)	1450	1600	1600	1950
	Conductive width (mm)	1070	1070	1070	1550
Band structure	Material	Carbon pure	Carbon impregnated of metal	Copper-Steel	Carbon pure
	Quantity	2	2	2 x (2 Cu + 2 Ca)	2
Band dimensions	Length (mm)	670	670	570 and 750	1030
	Width (mm)	60	40	25	50
	Height (mm)	16	16	7	25
Intensity picked up	Run	600 A	1200 A	3200 A	600 A
	Stopped	80 A	300 A	300 A	80 A
Mass (Kg)		8,7	9	2 X10	11

Where:

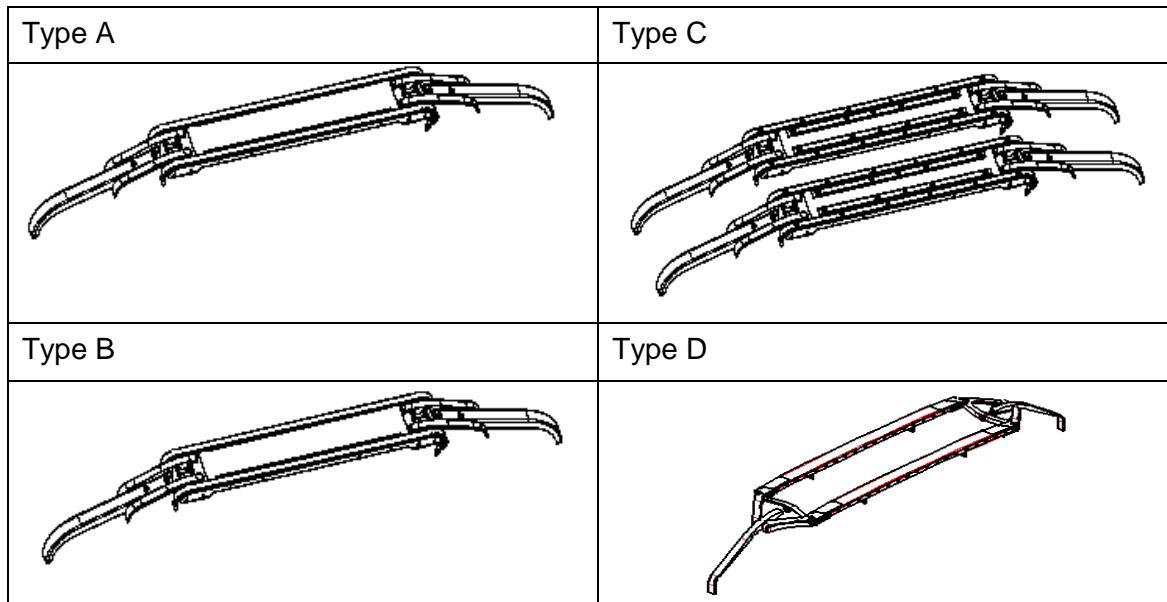



For FERRMED locomotive application the solution shall be:

Type C – with metal impregnated carbon strips for DC catenary

Type D – for AC catenary.

The system shall operate at normal speed between 120 and 140 km/h with top speed of 160 km/h.

The current collection system shall be based on 2 pantographs for DC current (1.5 and 3 kV) and 2 pantographs for AC current (15 and 25 kV).

Each couple of pantograph shall be controlled via electronic system which shall be adjusted to the right configuration for service based on the driver's selection and automatic selection. The setting parameter shall be at least:

- Network
- Configuration of pantograph (front or rear pantograph or double pantograph)
- Train configuration (1 or 2 loco)
- Speed
- Direction
- *Pneumatic command*: Biastatic for more safety, it should be use this one and not the monostatic.
- *Synthetic insulated 25 KV*
- *Damper*
- To improve the quality of abstraction, particular in the following cases:
 - Operates at high speed: $V \geq 140$ km/h.
 - Operates with multiple pantographs raised,

A rubber end stop shall be installed between the lower arm and the frame. This damping effect is simple, its effectiveness at intervening movements directed toward the bottom of the articulated system.

- Limitation of development

The limiting device extension consists of a retractable hook causing discontinuation of development of the pantograph. The race should be designed for each manufacturer.

- Auto Drop Device (ADD)

This device allows emergency automatic and quick lowering of the pantograph when carbon strip and / or the horn are damaged. In addition, after the (accident, a signal appears if repair is not done and pantograph cannot be raised again. ADD is based on a pneumatic valve mounted on the frame of the pantograph and operated by the air pressure drop of the pipe included in the carbon strip. The first part of the lowering stroke shall be fast as per EN 50206-1 chapter 4.9. The last part of the stroke shall be speed controlled.

- Protection tube for air supply

Multi air pipe connections consist of a rigid plastic tube and conical cups mounted on the tube itself to improve insulation.

-Air Pipe insulation

FERRMED FREIGHT LOCOMOTIVE CONCEPT STUDY



The air feeding pipe insulation is made of plastic tube; semi-rigid conical cups shall be supplied.

7.1.1.2 Other improvements in the power supply of electric locomotives

Medium-frequency transformer

Technology field: Optimisation of traction technologies

Overall potential: very promising

Description: Transformers have high losses at low frequencies. In 16 2/3 Hz railway systems transformer losses therefore considerably reduce overall traction efficiency. Modern power electronics allow for a more efficient and much lighter alternative: the medium frequency transformer operating at 400 – 800 Hz or comparable frequencies

Status of development: test series

Time horizon for broad application: in >10 years

Benefits (other than environmental): big

Barriers: medium

Impacts on energy efficiency: 2-5% (single vehicle); 1-2% (throughout fleet)

Vehicle - fix costs: medium

Infrastructure – fix costs: none

HTSC transformer

Technology field: Optimisation of traction technologies

Overall potential: very promising

Description: An innovative transformer concept based on ceramic high-temperature superconducting material instead of copper could considerably reduce transformer losses.

The main transformer accounts for a substantial share of traction losses. This is especially true in 16,7 Hz systems. An innovative transformer concept using ceramic high-temperature superconductors instead of copper as winding material could reduce the transformer losses almost to zero.

Possible applications of HTSC aim at

1. Optimisation of conventional equipment: motor, transformer, cable etc.
2. Development of innovative equipment: magnetic energy storage, current limiter etc.

Status of development: prototype

Time horizon for broad application: in >10 years

Benefits (other than environmental): big

Barriers: high

Impacts on energy efficiency: 5-10% (single vehicle); 2-5% (throughout fleet)

Vehicle - fix costs: high

Infrastructure – fix costs: low

FERMED FREIGHT LOCOMOTIVE CONCEPT STUDY

7.1.2 Diesel locomotives

Diesel traction is a key tool for the opening, growth and development of European rail freight transport, an essential policy objective of the European Union and the different countries.

Half of the EU27 rail lines are not electrified and even if the big rail European corridors are electrified most of secondary lines, which will be used as feeders or decongestion-lines for rail freight transport, are not electrified. Besides, diesel traction is used as well in shunting locomotives that operate at terminals and marshalling yards.

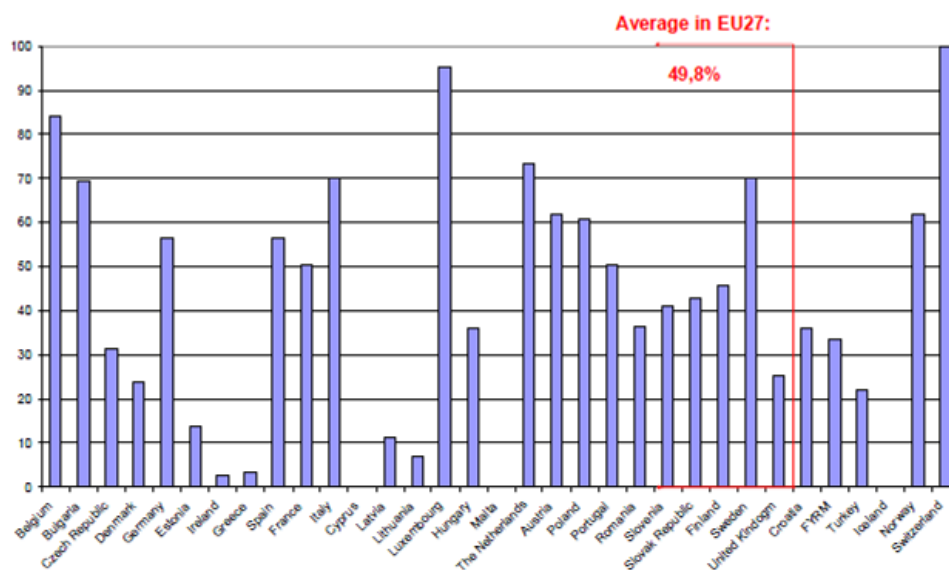

Source: Energy & Transport in figures, 2007. EC, Directorate General Energy and Transport

The use of diesel locomotives is much extended worldwide, especially in rail freight transport due to their flexibility and no-necessity of catenary.

Diesel locomotives are autonomous. The power is supplied by one or more diesel engine. That gives a great flexibility in the cross-borders operations but also in load/unload operations.

There are two types of Diesel locomotives:

- Diesel Hydraulic locomotives where the diesel engine transmitted the power to move a hydraulic traction system.
- Diesel Electric locomotives (more extended) where the diesel engine transmitted to power to a generator and then to the electrical traction motors that are on the axles. The traction motors are DC or AC. AC traction is the newest technology but both have advantages or disadvantages.

7.1.2.1 Diesel Engine

Diesel engines used in railways can achieve up to 4,5MW (the new one for China from GE and EMD) but in Europe have normally between 2 and 3,5MW.

Diesel engines can be two or four stroke depending of the manufacturer.



The **improvements** in diesel engines are focussed in reduce emissions, energy consumption and noise. Many innovations are already proven in small diesel engines used in road vehicles.

Some of these improvements are:

Common Rail

Technology field: Optimization of traction technologies

Overall potential: very promising

Description: In conventional diesel engines injection pressure is generated for each injector individually. A direct injection engine based on the common rail principle separates the two functions pressure generation and injection by first storing the fuel under high pressure in a central container ("common rail") and delivering it to the individual injection valves (injectors) only on demand. This way an injection pressure of up to 1,500 bar (in the future up to 1,600 bar) is available at all times, even at low engine speeds. The high pressure produces a very fine atomisation of the fuel leading to better and cleaner combustion.

Four basic components of a common rail system are:

- A high pressure pump with pressure regulator and inlet metering valve.
- A rail which contains a pressurised reserve of fuel.
- Injectors which inject precise amounts of fuel into the combustion chamber as required.
- A diesel control unit – the 'brain' of the system, which precisely controls injector flow and timing as well as rail pressure while continuously monitoring the operating conditions of the engine.

Status of development: in use

Time horizon for broad application: already exist

Benefits (other than environmental): big

Barriers: low

Impacts on energy efficiency: >10% (single vehicle); 1-2% (throughout fleet)

Vehicle - fix costs: low

Infrastructure – fix costs: none

Database of traction consumption

Technology field: Energy measurement and documentation

Description: A database containing traction energy data can provide reliable information needed for planning and decision making processes in railways.

Energetic optimisation of railway operation requires reliable and easily available energy consumption data. The most convenient instrument is a database of energy consumption figures. Such a database is fed by data obtained either through on-board energy measurements or simulation of train runs.

A powerful database of consumption data has to take into account the dependence of energy consumption on a variety of parameters such as:

- Train data (efficiency of traction components, train mass, aerodynamics, train configuration etc.)

FERRMED FREIGHT LOCOMOTIVE CONCEPT STUDY

- Train service (speed, distance between stops, timetable)
- Track data (topography, curvature etc.)
- Influence of driving style
- Influence of traffic situation (unscheduled stops etc.)

A database for energy consumption figures can be fed by data obtained by extensive on-board measurements or through simulation.

Status of development: in use

Time horizon for broad application: now

Benefits (other than environmental): medium

Barriers: low

Impacts on energy efficiency: -

Vehicle - fix costs: none

Infrastructure – fix costs: low

Diesel-electric vehicles with energy storage

Technology field: Regenerative braking and energy management

Overall potential: promising

Description: Modern energy storage devices permit the storage of braking energy on-board for use in the subsequent acceleration phase. This offers the possibility of an effective brake energy recovery in diesel-electric vehicles. Furthermore the peak demands on the diesel engines are reduced allowing for both downsizing of engine layout and better load management of diesel engines.

During *braking phases* the kinetic energy of the vehicle is transformed into another form of energy (e.g. electrostatic energy in the case of a capacitor) and stored in the storage device. When the vehicle stands still the energy storage device should be fully charged to be able to deliver energy during the subsequent acceleration phase. The power supply during acceleration is supported by the stored energy. The energy management system should be designed in such a way that the external energy supply never needs to deliver the full accelerating power (important condition to downsize energy supply!). When *driving at maximum speed* the storage device should be completely discharged.

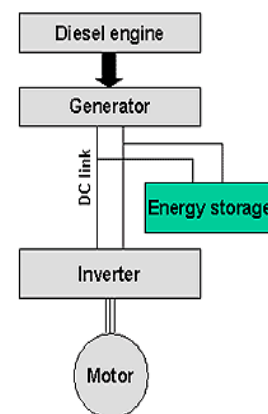

The best choice of an energy storage device heavily depends on the individual vehicle and service type. The following table shows the main characteristics to be looked at in an individual application context and the corresponding storage parameters.

Characteristics of application context	Corresponding parameter of storage device
Braking time	Charging time/power density
Braking energy	Energy density
Drive cycles in lifetime	Product life/reliability

Next diagram plotting energy density against power density is a convenient means to compare different storage technologies and assess their suitability for different vehicles.

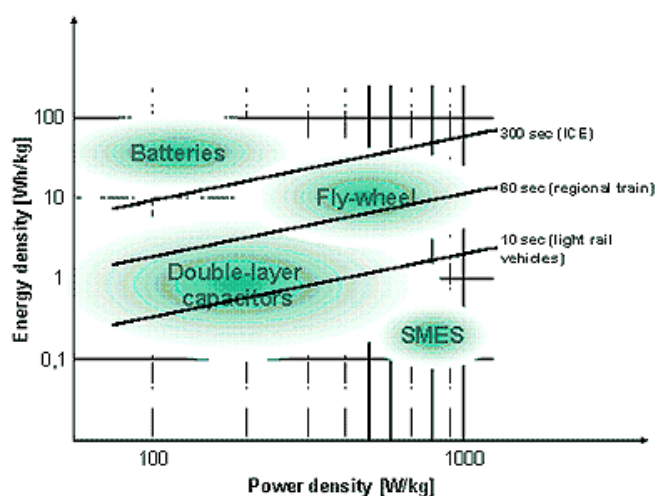

Status of development: test series

Time horizon for broad application: in >10 years

Benefits (other than environmental): medium

Barriers: medium

Impacts on energy efficiency: >10%

Vehicle - fix costs: high

Infrastructure – fix costs: none

7.1.3 Other type of locomotives

Hybrid locomotives are diesel locomotives that use batteries to reduce exhaust emissions mainly while idle.

Dual locomotives have the possibility to take power from the catenary when is available or from a diesel engine when the line is not electrified. So the operators have the same flexibility that a



diesel locomotive but reducing exhaust emissions and some advantages of the electric locomotives.

The main problems of both kind of locomotive, hybrid and dual, are the higher purchasing and maintenance costs respect diesel locomotives as well as the high weight due to the extra equipment.

In the future can also be possible other kind of energy supply equipment applicable to the locomotives like fuel-cell.

FERRMED does not want to limit the choice of energy supply and traction equipment. Any traction technology that helps the profitability of the railways is welcome. Rail operators should have opened all possibilities to use the kind of locomotive most suitable for its traffic.



7.2 Adhesion

Adhesion is inversely proportional to the speed.

There are different ways to calculate the adhesion and each administration use their own formula:

ADIF for example uses: $\mu = \mu_0 (0.2115 + 33/(V+42))$

Müller formula is common used: $\mu = \mu_0 / (1+0,01 V)$

Curtius-kniffer formula: $\mu = 1,161 + 7,5 (44+V)$

Adhesion coefficient (μ_0) means the quotient between maximum horizontal forces that can transmit a traction axle without wheel's slide and mass supported by this axle. μ_0 is also called *starting adhesion or static adhesion*

Then, if mass supported by traction axle of a locomotive is about 20 tons, and if the adhesion coefficient is 0,25, the axle only is able to transmit an horizontal force of $20.000 \times 0.25 = 5.000\text{N}$, independent of engine power. Therefore, horizontal effort depends on locomotive's weigh and the number of traction axles.

Adhesion coefficient is not constant. It depends on weather, wheel's shape, the head of rail, the pollution and control traction system.

Some **improvements** in the locomotive to increase the adhesion in different conditions are:

- Optimal electric motors power managing: Parallel connection.
- Developed studies on suspensions and guided axles.
- Precise knowledge about sliding and skating starting points.
- Also, It's developed a complete independence per axle, which allow a precise control of each axle and then improve the adhesion of the wheel on the track.

FERRMED's recommendations:

With all the improvements and innovations in the today locomotives, the different national norms should accept at least 33% adhesion coefficient (μ_0) and not 26% like many Infrastructure managers accept

FERRMED locomotive should work under following conditions:

- Environmental conditions: max 50 °C, min - 40°C
- Adhesion Limits: according to the UIC norms and national rules.



7.3 Coupling: Automatic freight coupler

Coupling is one of most important points at FERRMED. It connects different rolling stock in a train. The design of the coupler is standard (to plug and unplug different wagons), and is almost as important as the railway gauge, since flexibility and convenience are maximized if all rolling stock can be coupled together.

Coupling has to ensure the union between the locomotive and wagons, so to be safe for many different states that can be found during any trip. Also it's the connection by wire along different wagons (in spite of FERRMED's project includes the possibility about communications by radio) and has to be calculated to haul trains for 1500m as FERRMED Standards say. Another important thing is that it has to be easy to plug and to unplug each wagon from other one so what in these days cargo companies are spending lot of time on doing this action and sometimes it's a bit unsafe because shunting personnel have to be between one wagon and locomotive that's a dangerous place to be. To sum up, it's interesting to spend less time on it, to do it as fast as it could be possible and safe.

For all these reasons and some more, it's developed a new coupling to carry these specifications mentioned out before. Advantages in comparison to draw hook couplers with side buffer are:

- The automated coupling / uncoupling process results in faster coupling/ transportation processes and system velocity so less time is lost.
- Mechanical coupling as well as automatic pneumatic and automatic electric coupling at the same time so it increases the safe up. This is needed because the length of new train compositions.
- Centre buffer coupler with stabilizing link allows for longer trains, higher speed and increased safety against derailments.
- Reduced wear of wheels and tracks.
- Increased life cycles and reduced maintenance costs
- Reduced operating risk (serious or deadly injuries) of shunting personnel.
- Reduced operating costs
- At the next future, wagons could be plug and unplug from the locomotive by wire without shunting personnel so it would be much more fast and easy. At first times, it's working with a lever to do this action. Shunting personnel moves it to do the action.

From now on, it's shown different specifications about that:

- Horizontal and vertical stabilising linkage according to UIC-leaflet 523. This makes more difficult derailments because the wheel can never go out from the rail if always the coupler is at the same high so what it's a strong union together.
- Prevent light weight 2-axle vehicles from derailing up to compressive longitudinal forces of 700 kN.
- Limit resulting lateral forces on wheel set below app. 40 kN compared with 700 kN compressive force
- Integrated automatic air coupling (BP), not exceeding the SA-3 Willison Profile space envelope.
- Vehicle installation space acc. to UIC 530-1

Coupler head with long term service proven and accepted low wear
Tight-locking Willison Profile, compatible with SA-3 system

- Suitable for rough conditions (heavy industry, dusty + winter conditions) and heavy loads
- Compatible with side buffer rolling stock using UIC draw hook
- TSI certification
- Optional integrated electro-coupling for ECP Brake and Communication
- Uncoupling lever for manual uncoupling acc. to UIC
- Automatic centering device and supporting device
- Draft gear with reversible energy absorption
- Reduced weight (up to 200 kg lighter than UIC/OSShD coupler AK69e/Intermat)
- Compliant to UIC-leaflets 522, 523, 524, 530-1, 567-3, 829 RP0,2 of more than 1.000 kN (tensile load), resp. 2.000 kN (compressive load)
- Optional pneumatic air coupler with mixed air

Finally, it's mentioned which are cost saving potential by using a draw bar between two vehicles

- The cost saving potential depends on the coupler design. (Some features are available as option!)
- The estimated, average cost saving potential is about 20-25% , calculated on total cost of marshalling manpower and average rate of derailments / recovery .

As a conclusion, it's shown different pictures to take some ideas about this new coupler:

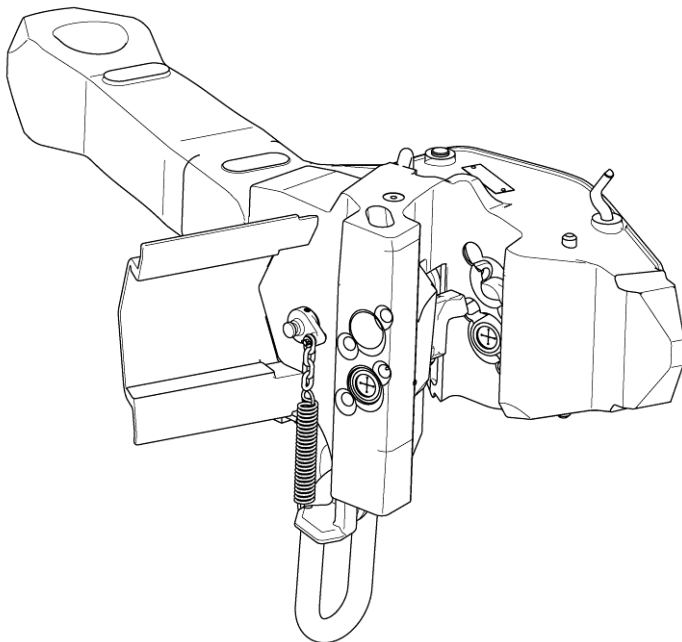

Here a draw about automatic freight coupler:

FT - TRANSPACT- Coupler

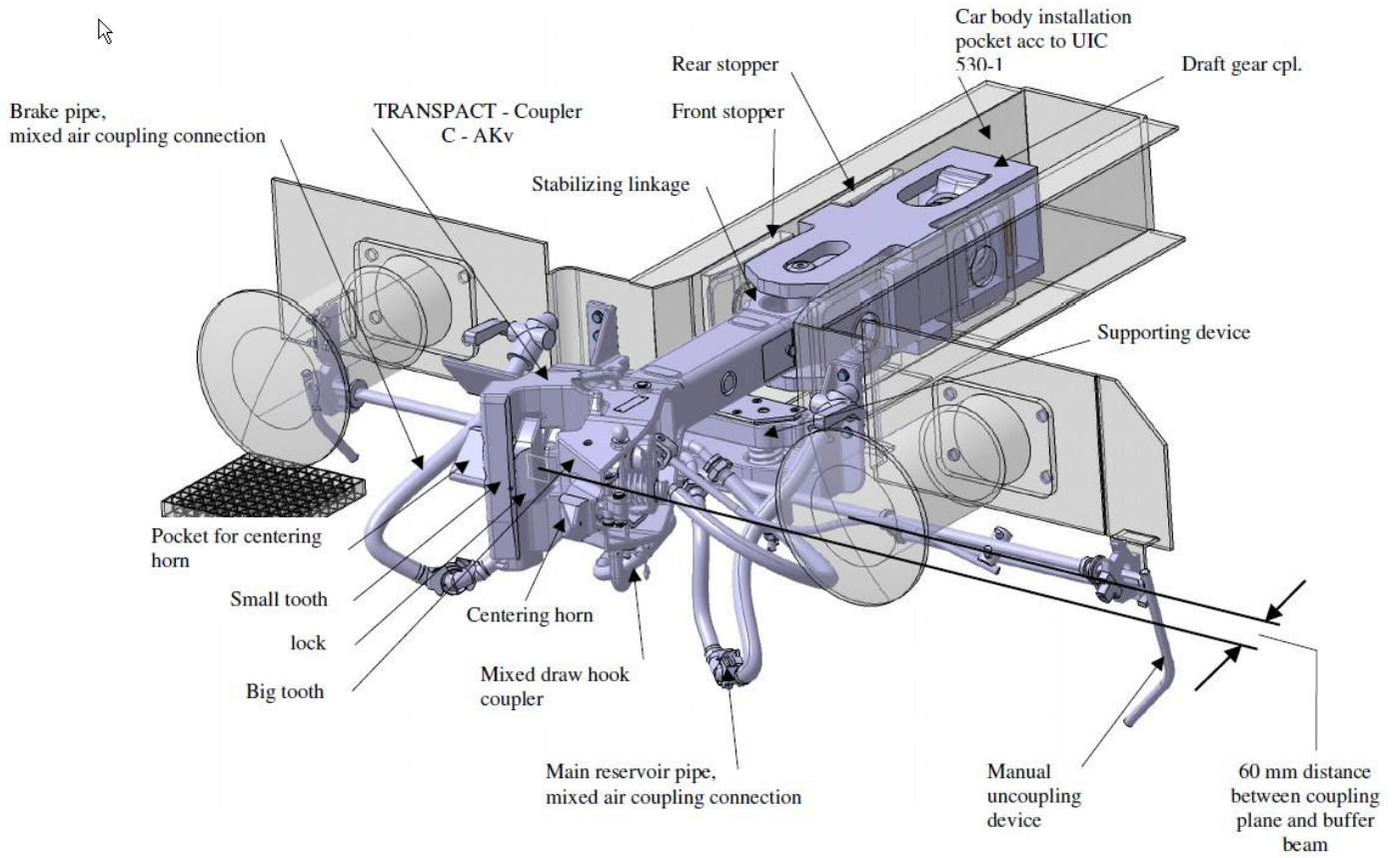

Coupling bar

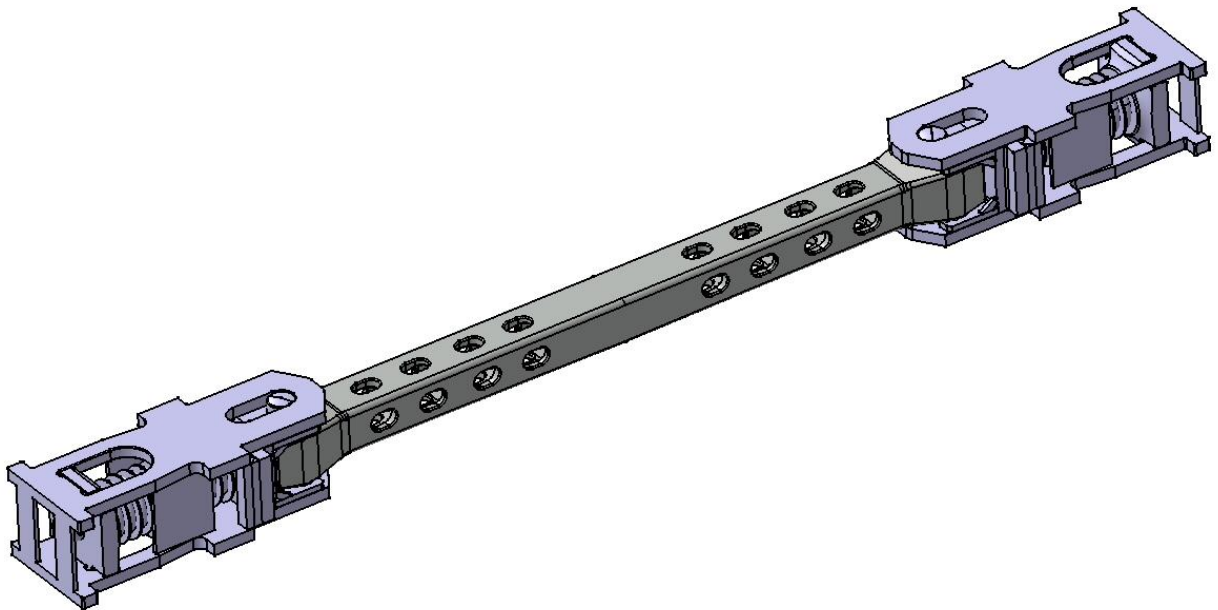



And here the different applications available with this type of coupler:

7.3.1 Actual coupling

Automatic coupler is compatible with the actual coupling used in all European freight wagons. That's really important because at transition period, both system will be used so it's an important thing that all wagons could be stuck all.



7.3.2 Russian coupling

Russia has its own coupling system and must be compatible with Ferrmed's coupling because exchanges are common between Europe and Russia. This is allowed with automatic coupler.



7.3.3 FERRMED coupling

Obviously, FERRMED coupling will be compatible with itself, as it was described at the beginning of this point



7.4 Multiple traction

General

As it was analyzed at chapter 4, FERRMED trains need two or more synchronized locomotives for each convoy. Two of the possible configurations are, for example:

- Two locos at the head of the convoy



- One loco at the head and other/s one in the middle or at the end of the train (today unusual): “pull and push” concept.



Nowadays, connection between locos is possible by wire when they are contiguous so it's possible to drive two locomotives with just one driver. More than 2 locomotives at the head of the train could exceed the maximum effort at the coupler.

For trains longer and heavier than the present ones, multiple distributed traction is necessary (“pull and push” concept). That is, to have one locomotive at the head and another or others in the middle or at the end of the train pushing the load instead of pulling it.

Today such kind of multiple distributed traction is possible with a driver in each locomotive who communicate each other via mobile telephone or walkie-talkies.

In order to operate, instead, such kind of train with just one driver, automatic communication between locomotives is needed. The communication system shall be safe and reliable and shall coordinate traction and braking on all the locos.

In a train configuration with a maximum length of 1500m, we can have:

- up to 6 consists;
- one Lead locomotive;
- one or more Remote Controlled locomotives.

The solution adopted and today in operation in USA and other countries is ECP, based on a power and communication line that connects all locomotives and wagons in the train (see “Train Bus” in the following diagram).

In order to manage, in Europe, a period of transition between the present situation and the “wired” trains, a radio communication system connecting the locomotives is needed.

The radio controlled operation of locomotives can also be deployed in the marshalling yards during train formation and brake test.

To use this system safe around all Europe, it should be ensure that frequencies use are not use at any other field like radio, TV or other systems that use any type of frequency so it should be reserve an special range of frequency for train's operations.

Radio Control Locomotive Architecture

The Radio system is composed of the following main components:

- Communication Unit - the Communication System controller consists of a power supply unit, microprocessor, transceiver and an antennas distribution frame.
- BCU - Brake Control Unit
- TRU - Traction Control Unit

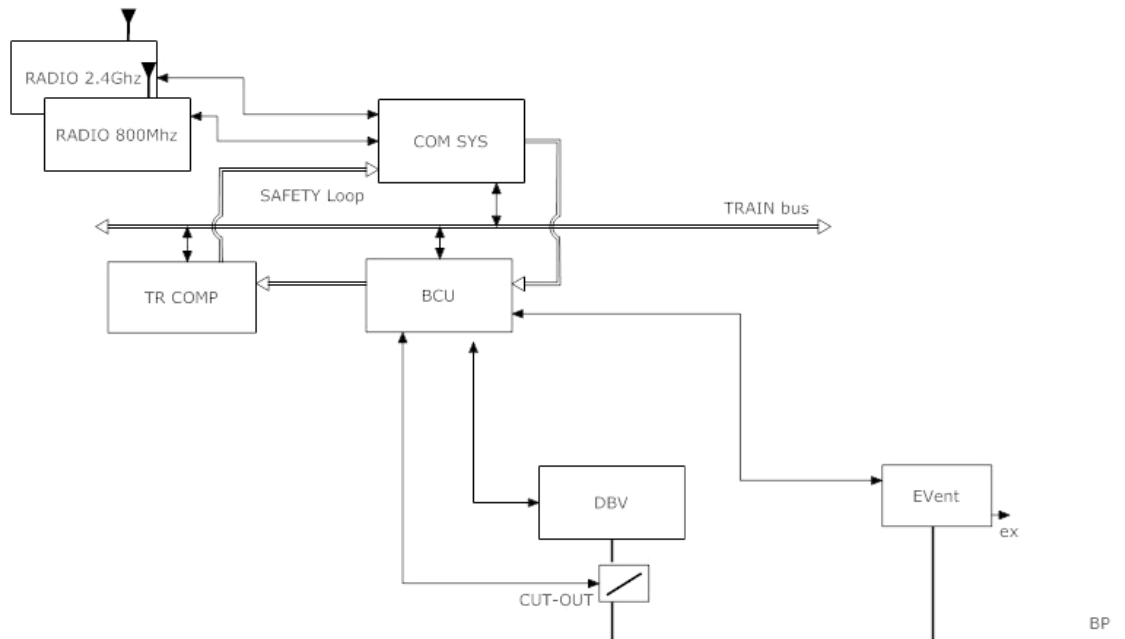



7.5 Brake system

Definitions

- ITC Inter-Train Communication network
- DT Distributed Traction system
- E-ECP Enhance-Electronic Control Pneumatic
- Consist: A contiguous series of locomotives, which may be controlled as a unique group. Locomotive consists can be either lead consists or remote consists. Lead consists contain the lead locomotive and any trail locomotives that are coupled to it and controlled via the xx connector and pipes. Remote consists contain one ITC-controlled unit and any trail locomotives that are coupled to it and controlled via the xx connector and pipes. Nominally, consists are separated by some number of freight cars. However, this definition allows back-to-back multiple consists made of single locomotives.

General

This architecture is in compliance with the TSI of the trans-European conventional rail system – Rolling Stock (IU-RST-24-11-2009-TSI draft 4.0 ‘Locomotive and passenger rolling stock’ and TSI freight ...).

It also satisfies UIC requirements (a Loco rescuing another train through the UIC pneumatic connection). There is a brake pipe which is the line to transmit the brake command through the train. In case of towing or towed operations the brake pipe will be controlled by the cab in towing vehicle.

The architecture consists of following main physical modules: the driver’s brake controller (handle) and the Brake Command and control module that could include air generation and treatment unit.

The following brake architectures could be used on the train up to 1500 length:

- **UIC brake system:** in the basic UIC compliant system the brake demand is transmitted as a pneumatic signal, the pressure drop value, by the brake pipe to all the cars of the train. The Brake pipe control is managed according to EN14198. Using the brake pipe only the length of the train is actually limited to 750m because of the physical limit in the transmission of pneumatic brake signal.
- **E-ECP brake system:** the amount of braking force requested to the train, whatever is the source (driver, automatic train control system, control and signalling system) is transmitted to all cars and locos of the train by a wired network. This system allows to each car to brake/release with same response time all along the train. It is possible to reach train length of 1500 m and train composed up to 100 cars.
- **Brake Radio Control:** in case of train composed by not wired wagons and two or more Radio controlled locos, this system allows distributed brake pipe pressure control. It is possible to reach train length of 1500 m and train composed up to 100 cars.

7.5.1 UIC SYSTEM CONCEPT

The UIC brake is a traditional pneumatic automatic brake system based on UIC 540 series of leaflets and it is composed mainly by:

FERRMED FREIGHT LOCOMOTIVE CONCEPT STUDY



- A driver's brake valve: it transform the movement of brake handle into a pressure value in a brake pipe and it is generally composed by brake handle (in the cab) and the electro-pneumatic portion DBV installed in the brake frame. The whole brake pipe is vented or filled by the master loco driver's brake valve (single point) and this limits the length of the train to max 750 m.
- A brake pipe that transmit brake demand along the train as reduction of pressure (automatic brake)
- An UIC homologated distributor: according to the drop of the pressure in the brake pipe it give a command signal to the relay valve that fill brake cylinder. One distributor per loco is permitted provide that the length of loco is according to the UIC rules and that a direct brake is installed.

The following blocks schemes show the UIC traditional brake architecture for the loco:

UIC brake system architecture

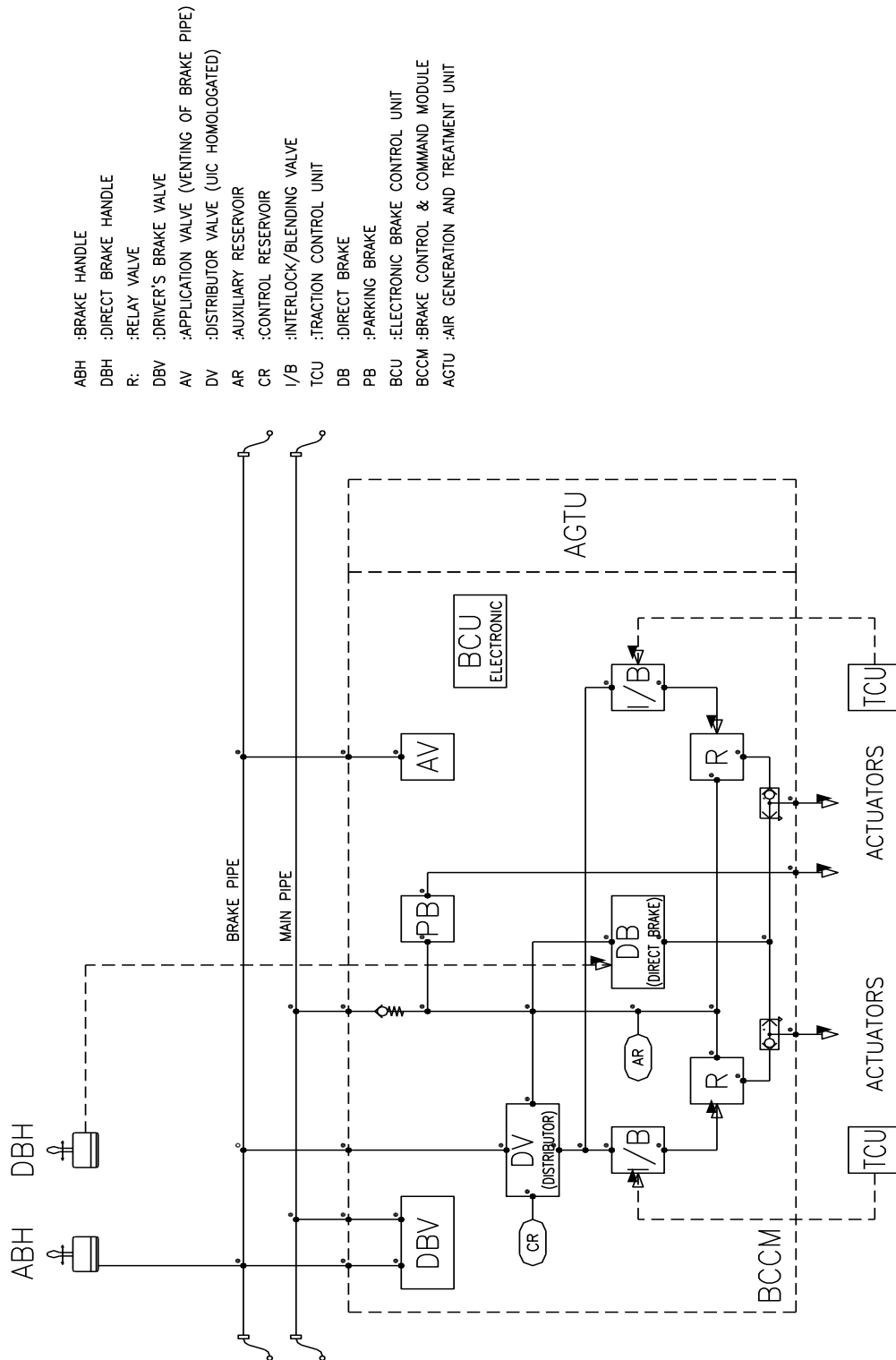



7.5.2 E-ECP SYSTEM CONCEPT

The E-ECP brake system is an Electronically Controlled Pneumatic direct type brake system.

It brakes and release the brake actuator filling and venting them in a directly way; when E-ECP system brake is in service the brake pipe is maintained at nominal pressure (5,0 bar) and brake and release operations are made by E-ECP system. The brake pipe it will vented in case of emergency brake or others emergency cases.

It is mainly composed by:

- A driver's brake valve: it transform the movement of brake handle into a electronic signal that is sent to each car by E-ECP lines. The pressure value in a brake pipe is managed only in emergency braking or when the E-ECP system is out of order. The E-ECP electronics and the electro-pneumatic portion DBV is installed in the brake frame. The length of the train t can be 1500 m because the brake and release operates at the same time on all the wagons.
- An electronically controlled pneumatic brake system is a train power braking system actuated by compressed air and controlled by electronic signals originated at the locomotive for service and emergency applications.
- A brake pipe that transmit brake demand along the train as reduction of pressure (automatic brake) for emergency cases. The brake pipe is used to provide a constant supply of air to the reservoirs.
- An UIC homologated distributor (or simplified): according to the drop of the pressure in the brake pipe it give a command signal to the relay valve that fill brake cylinder. It will operate in emergency cases. One distributor per loco is permitted provide that the length of loco is according to the UIC rules and that a direct brake is installed.

The E-ECP brake system , based on the Intra-Train Communication (ITC) network, provides power and communications to all E-ECP system brake devices in the train via a wired communication media that spans the entire length of the train.

The system provides almost instantaneous response to braking commands, including graduated brake releases and applications. The system responds appropriately to undesired separation or malfunction of hoses, cabling, or brake pipe.

The Enhanced Electronically Controlled Pneumatic (E-ECP) brake system is a train power braking system with better communication performance that should be used to improve the robustness and diagnostic capability of the train brake system and to add more train monitoring service (e.g. wagon coupling, door and load detection, ecc.).

The system provides the following levels of configurable functions:

- Lead:- the E-ECP central device at the locomotive is designated as "Master" by the driver
- Trail: the central device, when powered up, shall switch in trail mode. When in trail mode, it shall apply the appropriate E/P train braking
- Eot: the E-ECP equipment on the last locomotive in the train, if it is also the last vehicle in the train, may perform also the functions of the EOT (train integrity)

ECP Functions

The E_ECP control device is the core of the E/P brake system mounted within the locomotive



The E/P brake system mounted on the lead locomotive shall provide the following primary functions:

- Graduated brake applications and releases
- Continuous reservoir charging
- Continuous fault detection and equipment status monitoring
- Pneumatic Emergency brake
- Pneumatic Service brake back-up
- Monitor the end-of-train (EOT) device: train integrity function
- Provide a control signal to turn off train line power whenever communications with the EOT is interrupted or discontinued
- Provide a control signal to command a momentary train line power application to restart all wagon CCD and EOT devices that are shut down
- Provide mechanisms to conduct ECP brake system diagnostic tests
- Interface with locomotive system signals that interact with the train braking system
- Provide an interface to other locomotive system(s) with the intent of being able to provide appropriate locomotive retardation in conjunction with ECP train braking.

The following blocks scheme shown the E-ECP brake architecture for the loco

E- ECP architecture

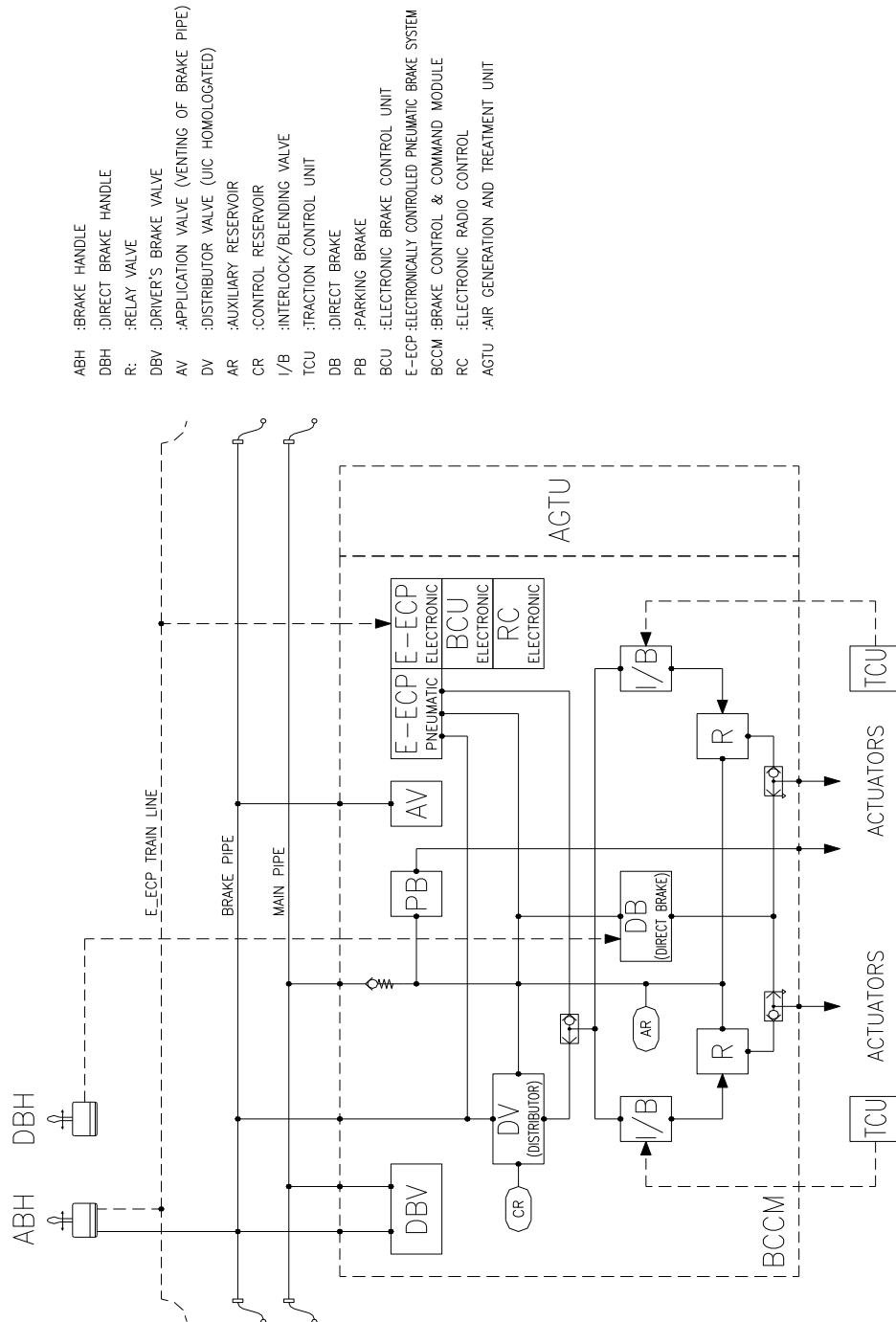



Brake Command and control Module

In normal operation, the following functional requirements apply to the Brake Command and control Module (BCCM):

1. To transform signals from the brake controller and/or other onboard control systems (e.g. ATC system) to generate a brake pipe pressure to be transmitted along the train (pneumatic portion of Brake pipe control unit); the control is in accordance to UIC 541-03
2. To transform signals from the brake controller and/or other onboard control systems (e.g. ATC system) to ECP braking system in accordance to AAR S-4200.
3. To interface to the loco control system e.g. for diagnosis.
4. The BCCM shall have an isolation device monitored (e.g. cock with electrical switch) able to be operated from remote control.
5. To transform signals from the train wide brake pipe to a corresponding brake cylinders pressure, taking optionally into account the loco speed.
6. To fill the brake cylinders, in case of venting of the brake pipe, with the corresponding pressure, taking optionally into account the loco speed.
7. To transform signals from the train wide ECP brake system to a corresponding discharging or filling train brake pipe.
8. To maintain the communication with the local traction control systems (according to the blending architecture).
9. To generate air compressed air by an Air Generation and Treatment Unit (AGTU)
10. To command and control parking brake

The brake cylinder pressure control shall be realised according to EN15355, however the brake cylinder pressure should not be limited to 3.8 bar. The brake control including the blending system should respect adhesion limits in accordance with the prEN15734-1.

The relay and load control function shall be realised in accordance with the EN15611.

ITC System specification

The heart of the E-ECP braking is the ITC network bus. It is used to convey power along the train and to command and control the various units in the network.

The ITC system should be designed in order to allow that the train traction control system working on multiple locomotives should be integrated with the E-ECP brake system within ITC network.

ITC specification is intended to ensure that functionality and performance are uniform and consistent among different manufacturers and that functionality and performance are interoperable.

Trainline network

Communication system shall be designed for a minimum of 100 network units spanning over 1500m

The wired bus shall be based on a redundant communication channel network: the ITC network is based on 2 bus channel, both working as a power line transmission media.

Communication Transceiver

FERRMED FREIGHT LOCOMOTIVE CONCEPT STUDY



The transceiver shall have an effective normal baud-rate of 30÷100kbps in FFC band (10khz to 450khz).

The transceiver coupling circuit shall provide transformer isolation from the train line communication media and be optimized to a 50ohm □transmission line.

ITC Communication Protocol

To promote the highest reasonable level of interoperability, all nodes using the electric train line communication media must fully implement the ANSI/EIA 709.1 protocol

ITC System Protocol

To promote the highest reasonable level of interoperability, all nodes using the electric train line communication media must fully implement the application messages described by the AAR-S4230 Standard.

ITC train line power supply

The ITC system power supply is a DC supply operating at nominally 230 Vdc to provide electrical power, via the train line, to all connected ECP wagon and EOT devices.

The power supply is mounted within a locomotive and is controlled by a power supply controller (PSC), which is a network device.

One single power supply shall be capable of supplying power to an ITC equipped train consisting of a minimum of 100 ECP wagons and an EOT.

Reference norm

- AAR S-4210 standard

ITC Locomotive Devices

ITC MMI

- Provide a man/machine interface to operate the ECP brake
- Provide a data display to the engineer
- Provide controls that allow the engineer to make brake and distributed power commands

ITC LCM

The LCM shall be capable of the following functions:

- Interface with the ITC communication network.
- Interface with the locomotive's propulsion, air brake, and auxiliary control systems for both control and feedback of the locomotive's control settings.
- Report MU controlled unit alarms to the lead locomotive.
- Interface with the locomotive propulsion control system for throttle and dynamic brake control.
- Interface with the E-ECP brake system for coordinated action during penalty and emergency brake applications.
- Interface with the locomotive automatic air brake system for coordinated action during penalty and emergency brake applications, and control the cut-in and cut-out of locomotive automatic brake.
- Interface with a man-machine interface (MMI) to allow the operator to control and/or monitor all necessary parameters of all locomotives under the operator's control



ITC PSC

The power supply controller (PSC) shall interface with the train line communication network and control a train line power supply as commanded by the LCM.

Multiple power supply devices may be enabled by the lead LCM.

Air generation and treatment unit (AGTU)

General

The AGTU shall be oil-free and is composed of the following main components:

- Compressor
- Air treatment unit
- Frame

The AGTU described herein could include any power conversion (e.g. DC/AC AC/AC static converters fixed or variable freq.).

The AGTU is provided with a safety valve (placed between compressor and air treatment unit) to protect the treatment unit against overpressures.

This document takes into account AGTU's installed inside the machine room or below carbody.

Performance

FEATURES	VALUE	UNIT	NOTES
AGU free air delivery at 9 bar Value indicates AGTU class; deviations are possible depending on supplier specific hardware	2300 to 3000	l/min	<i>Reference: 60 Hz. According to ModTrain/ModPower & ModBrake Nominal value tolerance measured according to ModBrake (TecRec tbd).</i>
Max air delivery pressure	10	bar	
Air quality after air treatment unit	Class 2-2-2		According to ModBrake (TecRec tbd)
Maximum losses for air treatment	<= 20%		Referred to AGU free air delivery



Bogie Brake Equipment

General

The bogie configuration defined by design and confirmed by brake and thermal calculations could be:

2 wheel-mounted brake disks each axle.

2 axle mounted brake disks each axle.

Tread brake blocks on the wheel for tread cleaning and conditioning (optional) and related actuator

The freight locomotive reference characteristics are:

- Axle load: 22.5 tons
- Rotating mass: 10 %
- Wheel diameter: 1250 mm
- Brake modes: G-P-R
- Deceleration:
 - 0.8 m/s² (P-mode)
 - 1.1 m/s² (R-mode)
- Maximum speed: 120 kph
- Thermal requirements: Tauern, Gotthard lines purely pneumatic

Interfaces

Mechanical Interfaces

Specification for wheel-mounted-disc

Wheel mounted disc:

- Fixation strength 100 g vertical shock
- Elastic fixation to the wheel web, to allow movements due to dynamic thermal expansion and coning
- Material: Nodular cast iron or steel

The weight of the equipment shall not exceed : 195 kg per disk.

Maximum dimensions of the module are: OD Ø1085 mm.

Specification for axle-mounted-disc

Axle mounted disc:

- 70 g vertical shock
- Radial guiding device, due to radial extension under thermal load
- Material: Grey cast iron or steel

The weight of the equipment shall not exceed : 125 kg. per disk.

Maximum dimensions of the module are: OD Ø640 x 110 mm.

Specification for related actuator

Compact Caliper with internal hanging links

- \varnothing cylinder 8“/9“
- Customized bracket
- Max Cylinder pressure: 3.8 bar - service
- Min Resetting pressure: 4.5 bar - parking brake, full release

The weight of the equipment shall not exceed: 84 kg/ 92 kg (without/with parking brake)

Maximum dimensions of the module are: 390x350 mm / 475x350 (without/with parking brake)

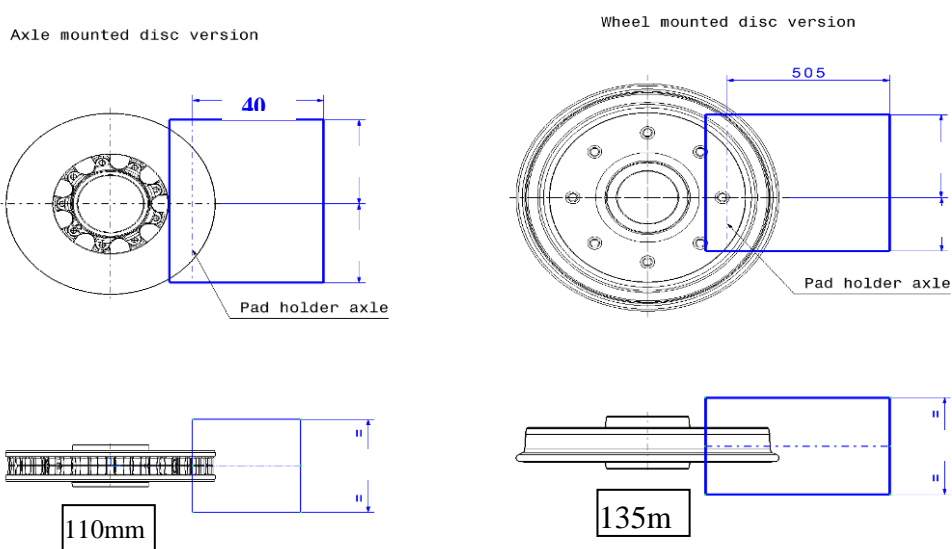

Maintainability requirements:

Disassembly of the actuator as a single part from the installed caliper

Disassembly of the complete calliper with 4 bolts

Installation requirements:

Isolation of rigid body vibrations between bogie structure and caliper

Caliper equipped with UIC pad holder.

Relation with FERRMED Wagon Concept

There is today compact integrated bogie brake equipment available and used on freight bogies. It allows weight saving of about 1 ton without modifications of the bogie.

However, the integrated bogie brake solution also allows a more weight-optimal design of the bogie-frame. Since the brakes work on one side of the each wheel only (on the sides towards the bogie center), front beams are not any longer necessary to support the brake equipment. A new bogie Y25Lsi-C without front beams (see figures) has been developed. If the bogie is adapted optimally to the new brakes total weight savings per wagon of more than 1.5 ton are possible (see table) .

Other advantages of the integrated bogie brake include:

- Low noise emissions due to small number of bearings with low clearance and vibration-damped suspension
- Modularized and standardized design with variable internal ratio
- Full automatic compensation of block and wheel wear
- Largely maintenance free also under severe environmental conditions
- High and constant efficiency, low hysteresis
- Less air-consumption, up to -60%

Due to the better brake performance, lower weight and cost savings the integrated bogie brake solution is foreseen as standard for the LMPW – and HCW-wagons of the FERRMED Wagon Concept. For the TOFW-wagon it remains to be investigated whether the solution can be built into the bogie with the smaller wheel diameter, as it is necessary for this wagon design.

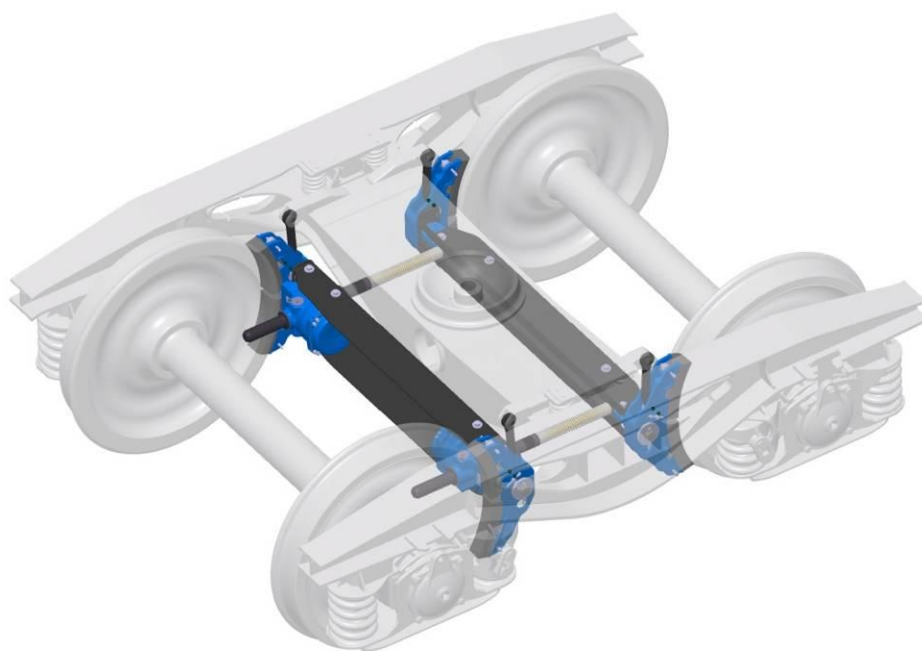

Picture of Y25 bogie with integrated bogie brake type BFCB:



8 CHARACTERISTICS TO ENSURE THE COMFORT, SAFETY AND SECURITY TO THE DRIVER.

“FERMED Locomotive” should also ensure the comfort, safety and security of the driver. Next it is described not only how should be the design of the driver’s cab but also the devices that facilitate the driving.

8.1 Driver’s cab

Normally in Europe there are two cabs (each one at each end) for mainline locomotives due to higher visibility.

The driver’s cab and desk should be designed including the latest state-of-the-art too.

As it has been seen before, the direction of running is not the same in all European countries. Future interoperable locomotives should have a central desk adequate to all countries.

Rail industry has worked together in the last years to develop the standards of such European desk. The project, called EUDD (European Driver’s Desk) in the first phase and EUDDplus in the second one, was coordinated by UNIFE and co-financed by the EC 6th Framework Program.

The project EUDD (European Driver’s Desk) *plus* aims at the development, in-field testing and validation of the interoperable, harmonised and modularised train driver’s desk. It’s useful to unify all European driver’s desk in one. It will improve the interoperability of the rail system in Europe.

Which are they objectives?

- To achieve a reduction of the Life Cycle Costs (LCC) of the system driver's desk of at least 15 % compared to the reference case.
- To justify the ergonomic advantages of the EUDD desk layout during in-field operation under day-to-day conditions.
- The shift of functions from the hardware to the software with enhanced flexibility, improved ergonomics and reduced costs → target: reduction of hardware controls by 30 % without any loss of operational performance.
- To facilitate the future series homologation procedure of the EUDDplus desk layout for all European networks.

Chain of Activities

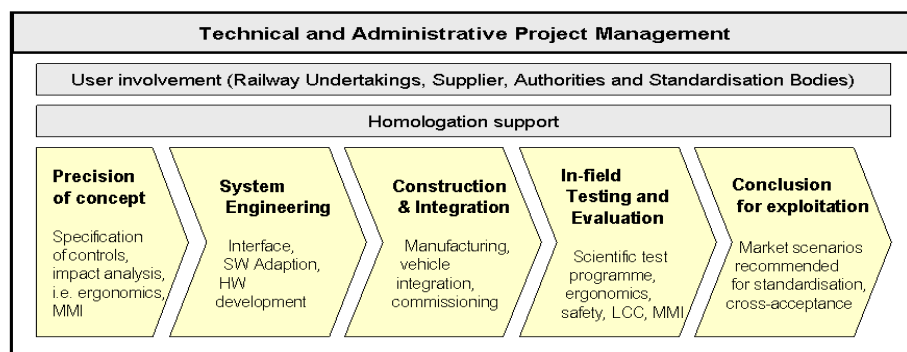

FERRMED FREIGHT LOCOMOTIVE CONCEPT STUDY



Advantages:

- Improved man-machine-interfaces (MMI) by applying latest knowledge in ergonomics/human factors,
- Improved passive safety because EUDD tries to make easy going when an emergency is happening.
- reduced number of hardware elements by shifting HW functions to SW functions
- harmonisation of the important operations

Interface Human Machine:

- In the standard position of locomotive is installed in the center of the cabin.
- The driver's seat and the control desk are arranged according to ergonomic principles to simplify tasks of driving and reducing driver fatigue.

Design of the table control:

- *The following items are located on the desktop:*
 - *On the left:*
 - *An emergency push button.*
 - *The automatic / back up brake handle with an emergency request on extreme brake position.*
 - *Direct brake handle.*
 - *In the middle:*
 - *Two push buttons for the driver's vigilance system.*
 - *Various switch for locomotive control (pantograph, VCB, lights , ..).*
 - *On the right:*
 - *The traction brake master controller which allows the driver to request a traction effort or electric braking.*
 - *On the five panels around table, they are:*
 - *Module for braking and pneumatic equipment control.*
 - *Main driving display unit (pressure of the main pipe, brake pipe and braking cylinder, overhead line voltage, traction/braking effort).*
 - *Module for speed indicator and signaling equipments.*
 - *Display for information about the state of the locomotives and the diagnostic system.*
 - *Module for the radio system.*

Here under some pictures of a prototype of a Locomotive PRIMA II in testing in Widenrath. This locomotive has incorporated the EUDD project.

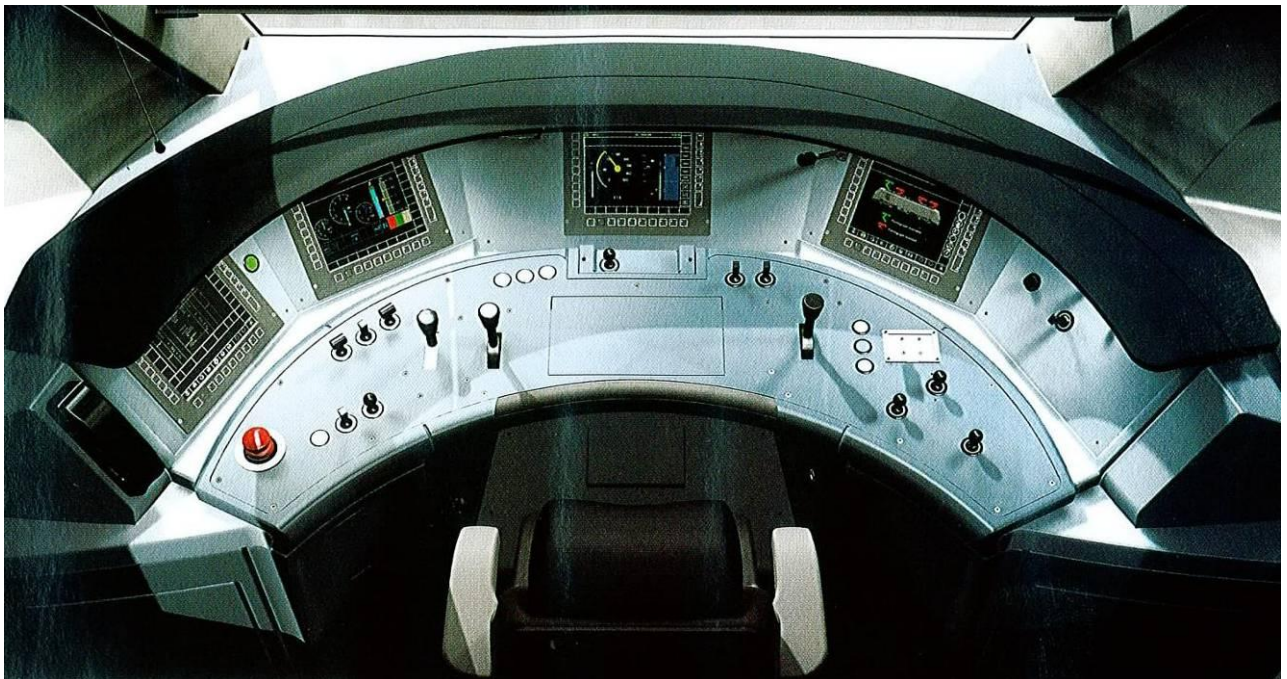

The driver's cab should also ensure the comfort and safety of the driver.

FERRMED FREIGHT LOCOMOTIVE CONCEPT STUDY

8.1.1 Safety

All locomotives must pass crash test and their respective safety rules to have a protection on train driver or other trains. Following issues should be taken into account:

- “Anti-collision protection”: Shock energy absorbing systems through sleepers fuses and caps deformable according to the TSI CR CRASH and EN15227.
- Crashworthiness requirements for railway vehicle bodies,
- EN12663 “structural requirements of railway vehicle bodies”,
- UIC 651 “Layout of driver’s cab in locos”
- Advanced fire systems.
- Greater visibility.
- Safety glass protects against impacts
- DIN5566 standards.
- UIC612 “Driver machine interfaces for locomotives and driving coaches”

8.1.2 Comfort

Drivers spend a lot of hours in the locomotive and therefore they ask for a comfortable working place with all needs covered:

- o air-condition and heating,
- o power outlet to heat water or coffee,
- o refrigerator ...

The cab should be also isolated to avoid noise and vibration inside it.

Ergonomic studies should be made when designing the desk to ensure that front the seating place the driver can easy see outside but also inside all information displays, he can easy operate all the control and he can stay all the time in his place in a comfortable way.

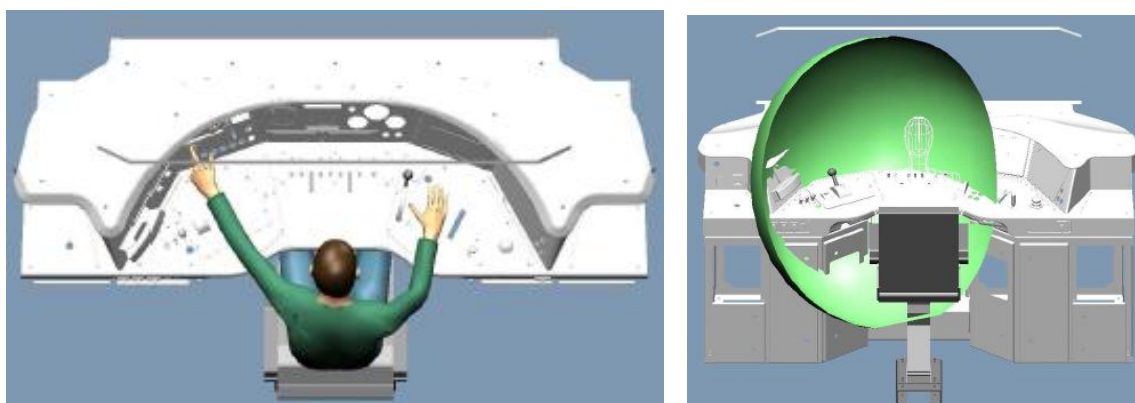

Summarizing the design of the cab:

- o 2 cabs per locomotive



- Integrated European desk (central position)
- Fulfillment all European standards referred to safety: Crashworthiness, Fire, and Visibility...
- Ergonomic design of cab and desk for the comfort of the driver.
- Isolation of the cabin to reduce noise and vibration inside.
- Air conditioning, heating, refrigerator and plug for use of driver.

8.2 Driving Advice Systems and other help devices

8.2.1 DAS

Driving advice systems are on-board tools giving recommendations to drivers for a more energy efficient driving style.

The driving pattern has a considerable influence on the energy consumed by a train on a given trip. For given restrictions (timetable, stops, speed restrictions on the way and installed traction power) a shortest time driving strategy can be determined, which is basically given by:

- Full acceleration up to maximum speed given either by speed limit or by maximum traction power
- Speed holding at maximum speed until train has to start braking
- Braking at the latest possible point in order to come to a stop when reaching the station

Current driving advice systems (DAS) calculate (and continuously update) the optimum driving strategy much more exactly than any driver could do. They are based on train positioning (GPS, Galileo or other), train, track and timetable data as well as algorithms to calculate driving recommendations.

Components of a DAS

A DAS requires essentially the following on-board components:

- Storage medium storing all the relevant data for an individual trip (infrastructure data, vehicle data, time table)
- Information system monitoring driving time and train position
- Computer unit using the above data to determine driving strategies and display them to the driver

Data supply

A DAS requires different classes of data to be updated in different time intervals:

- Permanent data: Vehicle data
- Long-term data: Track data base (to be updated annually)
- Mid-term data: Time table
- Short-term data: Data on temporary low-speed sections (to be updated daily or even in real-time), future options may include actual weather and track conditions as well.



All data are stored on-board on a flash disk. They are automatically updated via a W-LAN at several stations.

All of these systems are for:

- Optimizing the energy consumption
- Reducing the wear and tear on wheels
- Reducing tiredness of the driver.

There are also other devices that can facilitate the work of the drivers:

- o **Control and diagnosis systems** that help in the maintenance but also warn the driver when there are problems.

These systems record and process the data given by the sensors that are in the main equipment of the locomotives. The data can be used later by the maintenance workshop but also by the driver during driving. Before the problem appears, the driver is warned and can take in advance the required measurements.

- o **GPS device** to know the exact location of the locomotive if should be rescued.
- o **Communication system:** The driver should also have the possibility to communicate with the control center in any point of the route via telephone or via radio.

8.2.2 Automatic train control

Technology field: Energy efficient driving

Overall potential: not in freight locomotives

Description: State-of-the-art information and communication technologies allow for an automated driverless operation of insular mass transit systems. In long-term such options exist for railway operation in general. Energy efficiency effects can be achieved through general optimization of driving style and traffic flows.

Different degrees of automation can be discerned:

1. semi-automation with reduced driver control.
2. fully automated control as the sole operating system for driverless vehicles on autonomous, separate tracks.
3. fully automated driverless trains sharing a "mixed" infrastructure with driver-operated vehicles.
4. fully automated control as the sole operating system.

Driverless systems in freight operation are addressed in the context of self-propelled freight cars.

Status of development: in use

Time horizon for broad application: in > 10 years

Benefits (other than environmental): medium

Barriers: high

Impacts on energy efficiency: strongly dependent on specific application.

Vehicle - fix costs: medium

FERRMED FREIGHT LOCOMOTIVE CONCEPT STUDY



Infrastructure – fix costs: high

Vehicle - fix costs: low

Infrastructure – fix costs: medium

8.2.3 Driving advice system in freight operation

Technology field: Energy efficient driving

Description: Most freight trains do not have to obey strict time schedules but rather stay within certain time windows. On the one hand, this leaves more room for the energetic optimisation of the driving pattern. On the other hand, in mixed infrastructures passenger trains usually have priority over freight trains what leads to frequent unscheduled stops for freight trains. These unexpected stops impede the operation of a DAS. Railways with low traffic density and/or homogeneous freight operation therefore offer the greatest potential for freight DAS. This is the case in countries like the US or Australia, but also on individual lines in Europe. In cases where freight operation has a high density and or shares the infrastructure with passenger trains, DAS can only operate in an effective way, if the system takes into account the traffic situation. This requires a radio (or other) link to the control centre level with following data:

- Permanent data: Vehicle data .
- Long-term data: Track data base (to be updated annually)
- Mid-term data: Time table .
- Short-term data: Data on temporary low-speed sections (to be updated daily or even in real-time). This includes train configuration and vehicle mass which vary permanently in freight operation..

Status of development: research and experiments.

Time horizon for broad application: 5-10 years

Benefits (other than environmental): medium

Barriers: high

Impacts on energy efficiency: 2-5% (single vehicle) 1-2% (throughout fleet)

Vehicle - fix costs: low

Infrastructure – fix costs: low

8.2.4 LCC-driven procurement

Technology field: Management and organisation

Overall potential: very promising

Description: Besides product quality, cost is obviously a major factor in procurement decisions. The approach of life-cycle costing (LCC) considers the expenses of the customer along the entire life-cycle of the product. This includes capital costs (depreciation interest) and operation costs (energy, maintenance etc.). There is no canonical and standardized LCC concept for rail vehicles. Some LCC calculations include costs for operation personnel, costs of downtimes, costs for disposal, others don't.



The following table gives an idea of the relevance of energy costs in LCC (Costs for personnel are excluded, since some of the sources specified them while others didn't).

	Locomotive for freight service
Investment	11,70%
Energy	73,80%
Maintenance	14,40%

LCC is difficult to handle and cannot be given in a general and straightforward manner. The reason is its strong dependence on operational conditions, which vary between operators and may not be predictable for the future.

Status of development: in use

Time horizon for broad application: 2-5 years

Benefits (other than environmental): big

Barriers: big

Impacts on energy efficiency: -

Vehicle - fix costs:-

8.2.5 Switch-off of traction group

Technology field: Optimisation of traction technologies

Overall potential: very promising

Description: Most rail vehicles have several driven axles with separate power transmission. This includes both locomotives usually having a separate power train for each bogie and multiple units having several driven axles along the train. It is often feasible to shut off some of these driven bogies during partial load and operate the remaining ones at high load. Due to the fact that energy efficiency is usually lower for partial load than for maximum load, such a measure increases overall energy efficiency. This measure requires a change of the on-board software only, since individual motor bogies always have a switch-off option for the case of failure.

Status of development: in use

Time horizon for broad application: 2-5 years

Benefits (other than environmental): none

Barriers: **Impacts on energy efficiency:** medium

Impacts on energy efficiency: 2-5% (single vehicle); 1-2% (throughout fleet)

Vehicle - fix costs: low

Infrastructure – fix costs: none

FERRMED FREIGHT LOCOMOTIVE CONCEPT STUDY



9 ENVIRONMENTAL ASPECTS

On the one hand, the environment and sustainability have become priorities in Governments' agendas, companies and people. Increasingly, the focus is placed more and more on energy prices (fuel and electricity) and lower energy consumption is taken into account to improve the competitiveness of the companies.

On the other hand, it is expected that individual mobility, the daily commute to and from work or traveling on holiday, and the global flows of goods will grow in the future. The higher level of mobility is bound to bring a greater need for energy with it due to transport is one of the sectors that more energy consumes.

The intensity of this impact depends on the transport mode.

Railway is the most sustainable, environmentally and economically speaking, mode of transport for both, passenger and freight.

Technology is continuously developing and locomotives are a product with very long life, about 30 years. Locomotives should be designed with a modular concept to facilitate the retrofitting anytime is required.

Technologies to improve energy efficiency of the rail vehicles or to reduce environmental impact are appearing faster in the scene today that they ever did in the past. Some of them are replaced rapidly by new ones, some are still very expensive to put in operation or need an intensive maintenance and some have not yet been fully investigated. Many new developments, related to energy and environment, are expected to appear in following years.

9.1 Energy efficiency

Energy efficiency for railways means to reduce the energy consumption and, by this way, to reduce the energy costs and the emissions of pollutants and CO₂ whilst further growth of rail traffic.

Even though rail is more energy efficient than most other transport modes, the enhancement of energy efficiency is an important issue for Railways to reduce their contributions to climate change further as well as to save and enlarge competition advantages involved.

One key means of improving energy efficiency is to deploy advanced technologies. Therefore, the International Union of Railways (UIC) funded a project where all relevant railway energy saving technologies have been analysed, categorised and evaluated.

Low energy consumption is one of the most required demands of the operators to increase their competitiveness but also it is a priority of Governments and civil society.

Energy prices have experienced a big increase in the last years. Not only oil prices, electricity prices also. The trend is that these prices continue increasing in the future although 2008 was an unusual year with a big increase in the 1st. half 2008 follow by a suddenly drop in the 2nd. half of the year.

Following tables of Eurostat show *Producer Price Index (PPI) and Harmonised Index of Consumer Prices (HICP)* of Electricity, Gas and Liquid fuels for EU-27 taken 2005 as basis year.

Figure 8: Electricity, EU-27 (2005=100)

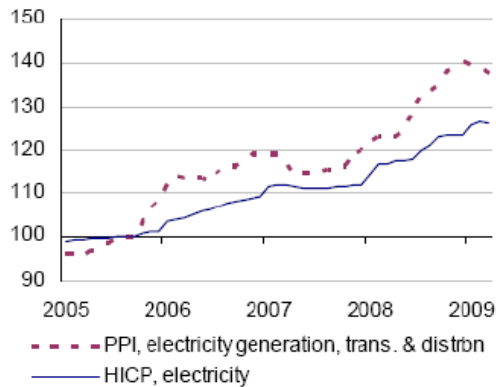

Source: Eurostat (STS, HICP)

Figure 9: Gas, EU-27 (2005=100)

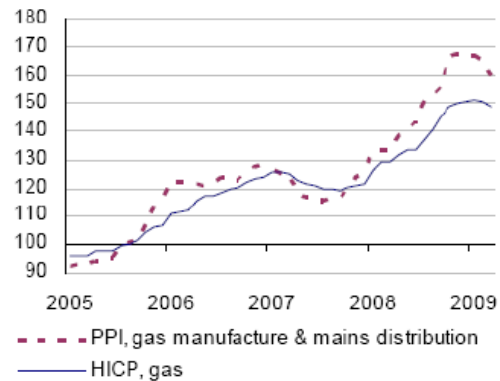

Source: Eurostat (STS, HICP)

Figure 10: Petroleum and liquid fuels, EU-27 (2005=100)

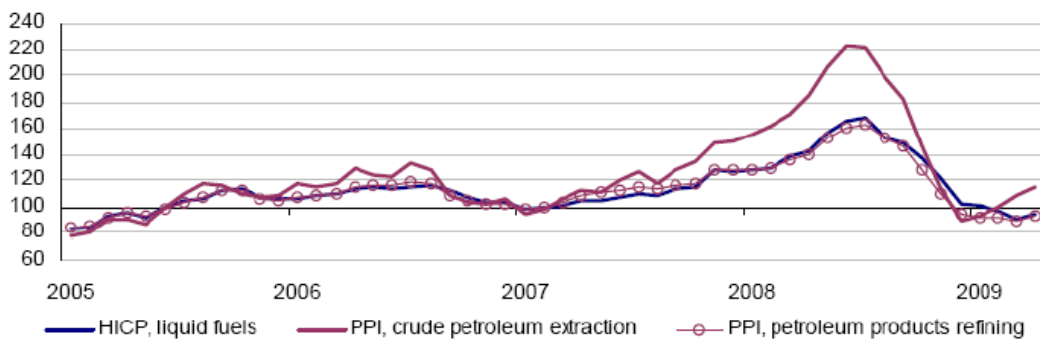

Source: Eurostat (STS, HICP)

In the rail sector, energy efficiency should be achieved by different fronts:

- Train operations management
- Innovations in the infrastructure side
- Innovations in rolling stock

9.1.1 Energy saving in train operations:

Energy can be saved during the planning of the operations taking into to account following parameters:

- Optimizing fleet and operational performance,
- Optimizing routes,
- Optimizing traffic flows,



- Optimizing mode of operation and train configuration defining maximum load by train in a determined route to get the best ratio payload/ energy consumption, that is the maximum possible payload with the lowest energy cost but avoiding delays.
- Selecting the appropriate technology to provide peak performance with the lowest operational costs

But also, energy can be saved during operations driving in an efficient and fuel-saving manner and reducing idling time.

Measurements of energy consumption made during several trips along the same line have shown that driving style constitutes a decisive factor that also affects the wear and tear on various mechanical components.

9.1.2 Innovations in the rolling stock

Most of manufacturers are developing **driver assistance systems (DAS)** and in the near future all locomotives will have incorporated such systems. These computer-based systems help the driver to run the locomotive with the optimum use of energy. The system processes various items of input data (weather, gradient, locomotive performance, train weight, train length, track conditions...) to recommend an optimum speed or tractive effort to the driver at each moment giving priority to arrive on schedule to the destination. Minimize also braking by automatically learning a train's characteristics.

With the incorporation of ETCS and GSM/GPRS on the locomotives the inputs to recommend the optimum speed can be change dynamically. So, trough a GSM/GPRS link it will be also possible dynamic adjustments to the timetable or ETCS will allow a dynamic update of the track status information provided on real-time by the train protection system.

Driver assistance systems (DAS) bring down the energy consumption but also reduce the wear and tear on wheels and brakes making rail operations more ecological and efficient.

Idle reduction of diesel Locomotives has a big potential to save energy. Diesel locomotives idle to protect the engine in cold weather, to keep engine warms to ensure its start (antifreeze is generally not used), to maintain batteries charged, to keep the comfort of the cab (heating), to maintain air pressure for braking but also due to ingrained operating habits or perceived futility of shutdowns of diesel engines.

Many fuel liters are consumed during idle to maintain the engine warm with temperatures under 0°. But fuel consumption is not the only problem created by idle, also exhaust emissions, noise, engine wear and higher maintenance costs. These problems are more severe in terminals and marshalling yards where locomotives are more time idle.

Future diesel locomotives will incorporate devices and innovations to reduce idling time and so to reduce fuel consumption. Some of them can be found in the market today. These systems allows idling locomotives to be shutdown by heating and circulating the coolant and oil keeping the engine warm, charging batteries, powering cab heaters. The use of one or other device depends on the service that the locomotive makes. All of them reduce fuel consumption, emissions and noise and can be applied in each locomotive.

- **Automatic engine start-stop control (AESS):** Microprocessor technology that automatically shuts down the main engine when a locomotive is not working. Lubricant and cooling fluid temperatures are continually monitored and the main engine is restarted if temperatures fall below a set threshold.
- **Locomotive Auxiliary Power Unit (APU):** System allows idling locomotive to be shutdown by heating and circulating the coolant and oil, charging batteries, powering cab heaters.

FERRMED FREIGHT LOCOMOTIVE CONCEPT STUDY



- **Locomotive Diesel Driven Heating System (DDHS):** same uses than APU. Variable engine speed generates optimum waste heat that heats water and oil.
- **Shore Power Plug-in System:** System allows idling locomotive to be shutdown by using shore power to heat and circulate coolant and oil, optional battery charger. Locomotive must be near an external power source to shut it down.
- **Hybrid locomotives** with batteries that power traction motors and do not idle.

There are other **on-board components** specifically designed to reduce energy consumption:

- **Latent-heat storage device:** the purpose of it is to storage heat of the diesel engine's cooling water to use it to warm the diesel engine to its starting temperature (40°). Thanks this device the use of the common pre-heating device (fuel-powered) is limited to some exceptional situations and so, fuel is saved. This storage heat would be otherwise dissipated to the environment trough the cooling tower.
- **Consumption measure systems:** the systems give drivers real information on the fuel or electricity they are consuming and their comparison with benchmark targets in this route. Drivers have a real-time feedback about their driving style. Rail operators can control their energy consumption and can take measurements to improve it by training the drivers.
- **Variable Speed Blower** adjusts traction motor blower speed to meet cooling requirements when a locomotive is in idle. The Variable Speed Blower offers fuel savings during idle by varying blower speed from fully off to fully on.
- **Recovery brake energy:** this technology is used already in light rail vehicles and it will be also possible for locomotives in a near future. The purpose is to store the energy releases by braking, instead of dissipating it on resistances, to reuse it during accelerating or for powering
- auxiliaries. This energy is storage by batteries, ultracapacitors or other devices. Electric locomotives have the possibility to return this energy to the catenary if the network allows it (at the moment is not possible).

Of course, energy can be also saved **improving performance of the traction system and of the auxiliary equipment** to reduce energy losses.

For electrical locomotives some improvements to increase the performance are:

- use of superconductors
- use of slippery materials in the contact between pantograph and catenary

Diesel engines are incorporating many innovations that make them more efficient and reduce also the exhaust emissions:

- improved injection and charging technology
- more efficient turbocharger
- optimised air cooling,
- EGR

FERRMED FREIGHT LOCOMOTIVE CONCEPT STUDY



Locomotive design is also a key point to reduce energy consumption. That includes different aspects of the locomotive:

- External shape to improve the **aerodynamic** and reduce the running resistance. Today it is an issue in passenger trains with potential energy saving of around 10%. It starts also to be incorporated in locomotive aerodynamic designs like CAD, CAE and CFC programs, tunnel winds...The purpose is to reduce tractive effort lost during driving due to aerodynamic pressure drag and friction.
- **Weight Reduction:** It can improve energy consumption but FERRMED trains required a big adhesion of the locomotive and that is achieved with more weight.
- **Reduction in friction** of all rotating elements of the locomotives and trains is another way to reduce consumption but also the wear and tear of the components.

Many new developments, related to energy and environment, are expected to appear in following years. Locomotives have a long life, around 30 years, so, locomotives should be able to incorporate these innovations simply and at a low cost. A good solution is the **modularity of the design** that allows the exchange.

9.2 Exhaust emissions

Diesel traction is a key tool for the opening, growth and development of European rail freight transport, an essential policy objective of the European Union and the different countries. But although diesel locomotives emit 3 times less exhaust emission per transported ton than the road, exhaust emissions and the pollution and global warming that they produce are still the main objection to diesel traction.

Even exhaust emissions have drastically decreased in past, they will decrease even more in following years thanks innovations and thanks the new emissions regulations from USA (EPA) and Europe that coming into force in 2016 and 2012 respectively.

Following tables show the emissions limits imposed by EU through the Non Road Mobile Machinery (NRMM) Directive 2004/26/EC with its two stages:

- o Stage IIIA mandatory in 2009
- o Stage IIIB mandatory in 2012.

Stage IIIA:

Category: Net power (P) (kW)	Carbon monoxide (CO) (g/kWh)	Sum of hydrocarbons and oxides of nitrogen (HC+NO _x) (g/kWh)		Particulates (PT) (g/kWh)
RL A: 130 kW ≤ P ≤ 560 kW	3,5	4,0		0,2
	Carbon monoxide (CO) (g/kWh)	Hydrocarbons (HC) (g/kWh)	Oxides of nitrogen (NO _x) (g/kWh)	Particulates (PT) (g/kWh)
RH A: P > 560 kW	3,5	0,5	6,0	0,2
RH A Engines with P > 2 000 kW and SV > 5 l/cylinder	3,5	0,4	7,4	0,2

Stage IIIB:

Category: net power (P) (kW)	Carbon monoxide (CO) (g/kWh)	Sum of hydrocarbons and oxides of nitrogen (HC + NO _x) (g/kWh)	Particulates (PT) (g/kWh)
RC B: 130 kW < P	3,5	4,0	0,025

The reduction of NOx and Particulate matters in Europe in the past and in the future is shown in following tables.

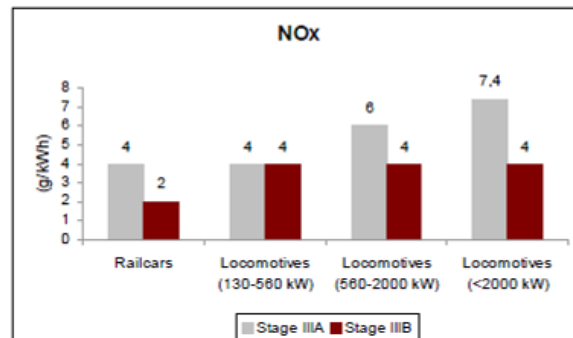
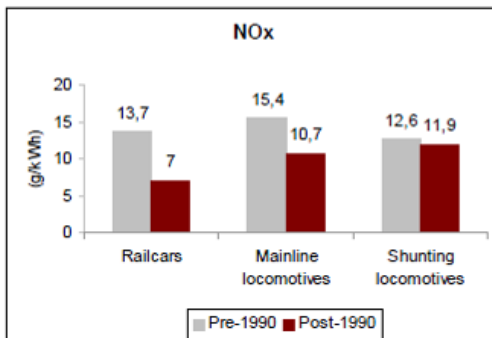

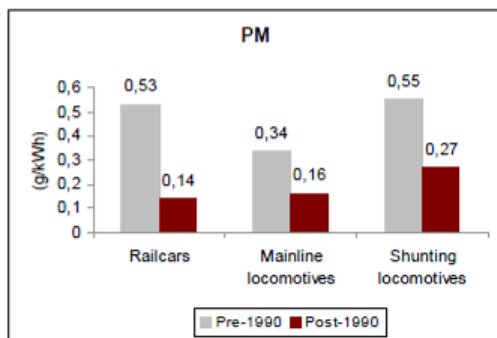

Source: Rail Diesel Study. UIC

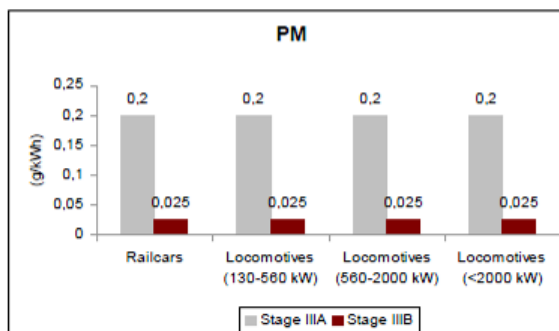

Source: NRMM-Directive 2004/26/EC

It is easy to see the big effort that the sector is making to reduce the pollution. It is indispensable a cooperation between engine manufacturers and locomotive manufacturers to achieve so low emission levels. Stage IIIB is similar to EUROV normative of the road.

According to the *Rail Diesel Study of UIC*, to fulfill Stage IIIA, it is just necessary:

- Lower sulfur fuel
- **Internal engine design improvements:**
 - o EGR (exhaust gas recirculation): it works by recirculating a portion of an engine's exhaust gas back to the engine cylinders. It is a technique used to reduce NOx.
 - o **Controlled combustion in-cylinder** (temperature, pressure drop, time, fuel quantity...)
 - o Improve injection and charging technology
 - o Optimize air cooling ...

But, to fulfill Stage IIIB, it is also necessary to have **exhaust after-treatment systems**. The most efficient ones are:

- **Diesel Particle Filters (DPF):** DPF is a device designed to remove diesel particulate matter or soot from the exhaust gas of a diesel engine. Wall-flow diesel particulate filters usually remove 85% or more of the soot, and can at times (heavily loaded condition) attain soot removal efficiencies of close to 100%.

In addition to collecting the particulate, a method must exist to clean the filter. Some filters are single-use (disposable), while others are designed to burn off the accumulated particulate, either through the use of a catalyst (passive), or through an active technology, such as a fuel burner which heats the filter to soot combustion temperatures, through engine modifications (the engine is set to run a certain specific way when the filter load reaches a pre-determined level, either to heat the exhaust gases, or to produce high amounts of NO₂, which will oxidize the particulates at relatively low temperatures), or through other methods. This is known as "filter regeneration". Sulphur in the fuel interferes with many "regeneration" strategies, so almost all jurisdictions that are interested in the reduction of particulate emissions, are also passing regulations governing fuel sulfur levels

- **Diesel oxidation Catalyst (DOC):** DOC reduces HC, transform CO into CO₂ and also decrease the mass of diesel particulate emissions (but not their number) by oxidizing



some of the hydrocarbons that are adsorbed onto the carbon particles. It is used in combination with DPF, for their passive regeneration. DOC converts NO in NO₂ that is used to oxidize the particulates of the filter.

- **Selective Catalytic Reduction (SCR):** it injects a small amount of Diesel Exhaust Fluid (DEF) – a water-based solution of urea – into the exhaust. Mixing DEF with exhaust in the presence of a catalyst turns NO_x into harmless nitrogen and water vapor. This is a highly effective way to reduce harmful emissions to the extremely low standards set by EPA and European Commission. The reduction of NO_x can achieve up to 85%-90%. Best of all, it allows the engine to be restored to more efficient state of operation for better fuel economy.

But, in the design of the locomotive it should be taken into account that the locomotive has to carry a urea tank, a catalizator and an injector to the exhaust.

The consumption of energy is the same with or without SCR but it should be considered that the locomotive will also consume urea (around 3%-5% of fuel).

Main problem is the required infrastructure to fill up the locomotives with urea. It is a cost that Administration Managers should assume in a short-medium time.

- ...

Other area where in the future many innovations are expected is the **combustibles:**

- diesel fuel with lower sulphur,
- new generation of biodiesel
- new alternatives like H₂

Last but not least, diesel traction can be complemented with batteries (**hybrid locomotives**) or electrical traction (**dual locomotives**) to maintain the advantages of the diesel traction reducing the total quantity of exhaust emissions. The main problems of this kind of locomotives are their high weight due to the new equipment, the higher price (acquisition cost) of the locomotive and the higher maintenance costs compare with the traditional diesel ones.

All the innovations and operational measurements described in point 9.1 *Energy Efficiency* will help also to the reduction of the exhaust emissions.

Summarizing, diesel locomotives have a small impact in the atmosphere and in the future this impact will be even lower. Technical and operational measurements will be introduced to reduce the pollution. Technically, there are 3 different areas where rail sector is working to reduce exhaust emissions

- Combustion: internal diesel engine improvements
- Exhaust after-treatment systems
- Combustibles

9.3 Noise emissions

Noise emissions of rail vehicles are regulated by *TSI-Noise* or *Technical Specification for Interoperability relating to the subsystem “Rolling Stock-Noise” of the Trans-European Conventional rail system* since 2006.

Noise emitted by locomotives, multiple units and coaches subdivides into stationary noise, starting noise, and pass-by noise. The noise within driver's cabs is also considered.

- The stationary noise is highly influenced by auxiliaries, such as cooling systems, air conditioning and compressors.
- Starting noise is a combination of contributions from traction components such as diesel engines and cooling fans, auxiliaries and, sometimes, wheel slip.
- Pass-by noise is highly influenced by the rolling noise, linked to the wheel/rail interaction, which is a function of speed. The rolling noise itself is caused by the combined wheel and rail roughness and by the dynamic behavior of the track and wheelsets. At lower speeds the noise of auxiliaries and traction equipment is also significant.

Multiple units are fixed trainsets either with distributed power or with one or more dedicated power cars and coaches. Multiple units with electric traction are abbreviated as ‘EMUs’, while those with diesel traction are abbreviated as ‘DMUs’. In this TSI the wording ‘diesel’ or ‘diesel engine’ includes all forms of thermal engine that are used for traction. Fixed formation trains that consist of two locomotives and coaches cannot be considered as multiple units if the locomotive can operate in different train configurations. The emitted level of noise is characterized by:

- Sound pressure level, according to a defined measuring method,
- Microphone position,
- Speed of the wagon,
- Rail roughness,
- Dynamic and radiation behavior of the track.

Limits for stationary noise

Vehicles	$L_{pAeq,T}$
Electric locomotives	75
Diesel locomotives	75

Limits for starting noise

Vehicle	$L_{pA_{Tmax}}$
Electric locomotives P < 4 500 kW at the rim	82
Electric locomotives P \geq 4 500 kW at the rim	85
Diesel locomotives P < 2 000 kW at the shaft	86
Diesel locomotives P \geq 2 000 kW at the shaft	89

Limits for pass-by noise

Vehicle	$L_{pA_{eq,Tp}}$ @ 7,5 m
Electric locomotives	85
Diesel locomotives	85

The interior noise level of passenger vehicles is not considered to be a basic parameter. However, the noise level within the driver's cab is an important issue. Noise levels in the cab must be kept as low as possible, by limiting the noise at the source and by appropriate additional measures (acoustic insulation, sound absorption).

Limiting values $L_{pA_{eq,T}}$ for the noise within the driver's cab of electric and diesel locomotives are:

Noise within the driver's cab	$L_{pAeq,T}$	Measurement time interval T
Standstill (during external acoustical warning with the maximum sound pressure of the horn, but less than 125 dB(A) at 5 m ahead of the vehicle in 1,6 m height above head of rail)	95	3 s
Maximum speed, applicable for speeds less than 190 km/h. (open country without interior and exterior warnings)	78	1 min

Improvements and Innovations in locomotives relating noise are:

- Improvements in materials and design of the bogies and wheels helping to reduce the impact of track irregularities in the outbound noise.
- Acoustical improvements in engines, compressors and brake and main noise sources such as fans
- Improvements in the definition of control strategies to bring down the emissions of noise of those sources.
- Reduction of the friction of rotating elements and new materials
- Aerodynamic designs of car body and cab structure
- Suspension technologies of the critical elements reducing solid noise
- Simulation of the vibratory performance of the structures by FEM and validation of results
- Replace the shoe brakes by disc brakes. But the main noise comes from the wagons, and we can also imagine wagons equipped with disc brakes. Of course the cost of disc brakes will be higher than the shoe brakes.

9.4 Recycling materials

The choice of the materials for trains manufacture must be run by precaution, economical, reusing and recycling principles. Also, it has to be care about available technology and level of knowledge existed. Manufacturers have to add the list of materials that they are using to make their trains according to actual norms and restrictions about that. A document about the reason or reasons why these materials are being used, where they are being used and which are alternative materials instead of other ones has to be add too.

About use of each material and substances will be contemplated when and why it is used one material instead of another one. For example, copper can be used for electric installations but it can't be used at the brakes manufacturing because it has a high pollution in contact with atmosphere, water or the floor.

All materials used have to be evaluated environmentally. The use of some materials is regulated by international agreements like arsenic, cadmium, chromium, copper, lead, mercury, nickel, zinc and its compounds. To reduce define the life cycle of their trains, the spares that must be changed during the life cycle and their possible generation and disperse of pollution during the period of use. Also it will be added they recyclability and reusability.

To reduce the consumption of natural resources and pollution, the manufacturer must define the life cycle of their trains, the spares that must be changed during the life cycle and their possible generation and disperse of pollution during the period of use. Also it will be added they recyclability and reusability.

Here an example about materials and their recyclability:

Materials	Recyclability rate (%)	Materials	Recyclability rate (%)
Steel	95	Rubber	98
stainless steel	95	Polyamide	98
Aluminum	95	PVC	
Brass	95	Other polymers and resins	98
Alloys	95	Electronic	100
Copper	95	Charged polymers	100
Wood	100	Fibers	100
Textile	98	Oils	80
Glass	95	Fats	
Polyester	98	Others (refrigerants, chemicals...)	75

Future locomotives have to contemplate from design, the whole life of locomotive and all components must be taken into account. They locomotive should incorporate a big percentage of recycling materials (about **90-95%** recyclable following the **norm ISO 22628**).

Locomotives will also follow **ISO 14025** environmental product declaration, which allows their environmental impact to be evaluated throughout their lifecycle.

Following are the environmental commitments of rail sector relating to the used materials:

- Promote the manufacture of products certified ISO 14001.



- Design and manufacture minimizing their impact on the environment.
- Reduce contribution to global warming.
- Respect and anticipate all legal and regulatory requirements.
- Materials:
 - reduce quantities
 - Increase recyclability using green materials.
 - Maximize durable use of renewable resources
 - Reduce risks of dispersal of toxically substances
 - Control & minimize the use of dangerous substances
- Energy ⇒ Reduce energetic consumption
- Techniques for clean production
- Efficient distribution
- Impacts reduction during use phase
- Increase durability of the products
- End of life optimization



10 TRANSITION PERIOD

FERRMED has defined the European freight locomotive concept for the future, but this locomotive has to co-exist and operate with the actual ones in the existing infrastructures during a long period (until renovation).

We have to also define how to manage the transition period.

The State-of-the-art in Europe:

1. Couplers are not automatic.
2. Long braking distances.
3. No distributed multiple traction. Multiple traction with one driver is only possible with two locomotives in the head. Other configurations require at the moment one driver per locomotive.
4. Length shorter than 1500m in siding and marshalling yards.
5. Countries are gradually installing ERTMS on some of their train lines but still it is not full in operations along the FERRMED Great Axis.
6. Interoperability is still not a reality

Stages to solve the interoperability problems in Europe:

1. Cross-Acceptance agreements between all EU countries to speed the homologation process of the rolling stock
2. To solve the infrastructure barriers that avoid the interoperability between EU countries. In the European Rail Freight Core Network: track gauge should be 1435 mm along the corridors; train gauge and maximum train length should be the same in all corridor, installation ERTMS...
3. EU Countries should finish the installation of ERTMS in their rail lines belonging to main freight corridors of Europe (Rail Freight Core Network). Until ERTMS is fully implemented, locomotives and trains must have installed the safety systems of all countries where operate.
4. Finish the redaction of the TSI and make them mandatory for all countries and cross-border rolling stock
5. To extend interoperability solutions of EU Rail freight Core Network to all European rail lines to make an gradually unique European Rail Network.

Stage to increase the length and load of the freight trains:

1. To increase the length of siding and marshalling yards to allow the formation of trains of 1500m. or search new terminals locations where the extension is not possible. Take this into account also in new lines and terminals to be built along the EU Rail Freight Core Network and
2. Nowadays multiple traction is used with 2 locomotives in the head of the train operated by 1 driver. The other solution with one locomotive in the head and other in the middle is less used. For one hand, it is better to relax the efforts on the couplers, which are not



automatic, but this configuration needs now two drivers because is not possible via radio the remote control of the second locomotive.

3. When ERTMS level 2 is installed in whole EU Rail Core Network, it will be possible to operate trains with distributed multiple traction and 1 driver. The communication between locomotives will be made then via radio,
4. To change gradually current coupling to automatic coupling that is compatible with current screw coupling and to implement E-ECP brake first to the new rolling stock and afterwards to the present fleet of locomotives and wagons with an “European overhaul program”
5. when the couplings allow it, locomotives and wagons can be wire-connected



11 CONCLUSIONS AND RECOMMENDATIONS

The final objective of FERRMED Standards, of FERRMED Freight Locomotive Concept and FERRMED Wagon Concept is to increase the competitiveness and profitability of the freight transport in Europe to reduce logistics costs of the companies making them more competitive.

To achieve this purpose, FERRMED proposes:

- To increase the length and the load of the train to 1500m and 3600 ÷ 5000 tons with 22.5 tons per axle (in the future 25 t/axle). Up now called “FERRMED trains”.
- To allow the free circulation of freight trains at least along the European Rail Freight Core Network. Due to the barriers (legal, political and physical) that traditionally the countries have made to international rail traffic; interoperability is one of the main issues that European locomotives should solve.

Conclusions of this study are:

1. More power does not mean more load. More powerful locomotive allows operations at higher speed and acceleration, but there are other parameters that define if a load can be hauled or not and if this train can start or not. These parameters are:
 - Gradient of the slopes
 - Type of coupling
 - Adhesion
 - Starting tractive effort of the locomotive
 - Adherent weight of the locomotive/s.
2. **Starting tractive effort** required to start and to haul “FERRMED trains” in slopes of 12‰ are between 600kN and 800kN depending on the total tons transported. That is double than current European locomotives have (300kN have Bo-Bo locomotives, 400kN have Co-Co locomotives), therefore, it will be necessary more than 1 locomotive to haul “FERRMED trains”.
3. **Adherent weight** of the locomotives increases with the number of motorized axles of the locomotive and with the axle load. Under European infrastructure constrains (maximum 22,5 t/axle) at least 12 axles are required to haul “FERRMED trains”.
Therefore, although in terms of purchasing costs, operational costs or maintenance costs... it will be more competitive to operate “FERRMED Trains” with just a powerful locomotive; it is necessary at least 2 Co-Co locomotives or 3 Bo-Bo locomotives to start such trains of 3600 t ÷ 5000t in slopes of 12‰.
4. Limitations of **adhesion** by the Infrastructure Administrations should be revised and updated. Thanks to new technologies, current and future locomotives can achieve better adhesion coefficients than former ones with just electromechanical adhesion control systems. FERRMED recommends accepting at least an adhesion coefficient (μ) of 33%.
5. The **total power** required to haul “FERRMED trains” in an adequate speed will round 7.000 KW to 10.000 kW. But, it is enough that FERRMED Locomotive has 3.500 KW to 5.000 KW with the capacity to operate in multiple traction. Anyway, more powerful locomotives have advantages respect speed and acceleration.
6. Power can be supplied by the catenary, by diesel motors or by any new energy supply technology feasible in the future: fuel-cell, batteries ...



7. **Couplings** with higher resistance as the current screw coupling are also required. Automatic coupling is the best option in terms of resistance and safety but also to allow longer trains than current European ones. The coupling should be universal for all types of European locos and wagons. It should also be compatible with Russian coupling and during the transition period, it should be compatible with current screw coupling.
8. FERRMED locomotive should be **interoperable**, so they should meet following requirements:
 - Fulfill all applicable TSI, European Directives and national-specific norms
 - Be homologated for all countries where it will operate
 - Track gauge: 1435mm
 - Diesel or electrical multi-tension locomotive at least until the whole Freight Core Network has the same voltage, 25kV
 - Equipped with European Central Driver Desk.
 - ERTMS should be the communication system between train and rail, replacing the system used in each country actually. FERRMED Locomotive should be able for ERTMS level2: equipped with ETCS and GSM-R radio system.
9. FERRMED locomotive must allow **distributed multiple traction**. The communication between locomotives can be wireless (via radio) or wire-connected.
10. FERRMED locomotive should have the capability of communication with the wagons.
11. **Brake system** must be E-ECP (Enhanced-Electronically controlled pneumatic system)
12. FERRMED locomotive should ensure the comfort of the driver but also the safety of driver and load.
13. FERRMED locomotive should have also a commitment with the **environment** including all innovations to reduce noise and exhaust emissions but also the energy consumption. Locomotive must be recyclable as much as it could be possible (around 90 ÷ 95%), producing minimum pollution as possible and be silent and efficient as much as it could be possible.
14. Many of the innovations of the FERRMED Freight Locomotive Concept are already developed but still not implemented. The total implementation of some of them like ERTMS, automatic coupling, E-ECP brake, distributed multiple traction via radio or wire-connected... will require still some years. During this **transition period**, rolling stock should incorporate gradually the innovations.



12 SUMMARY: HOW IS FERRMED FREIGHT LOCOMOTIVE?

Characteristics "FERRMED Trains"	
Length	1.500m
Gross Weight = Load	3.600 t ÷ 5.000t
Number of motorized axles	12 axles
Number of locomotives	More than one: 2 Co-Co or 3 Bo-Bo
Starting tractive effort of the train	600 kN ÷ 800 kN
Power of the train	7.000 kW ÷ 10.000 kW

Characteristics FERRMED Freight Locomotive	
Starting tractive effort of the locomotive	300 kN ÷ 400 kN
Power of the locomotive	3.500 kW ÷ 5.000 kW
Axle load	22,5 t/axle ÷ 25 t/axle
Axle arrangement	Co-Co or Bo-Bo
Maximum speed	120 km/h
Track gauge	1435 mm
Loading gauge	UIC C
Adhesion coefficient (μ_0)	At least 33%
Type of traction	Diesel locomotive or electrical multi-tension locomotive
Pantographs (for electric locos)	Two devices type C and two Type D
Multiple traction	YES, distributed traction (not only locomotives on the head of the train)
Coupling	Automatic with capability to connect current UIC screw couplers and Russian couplers.
Brake	E-ECP Brake System (Enhanced-Electronically controlled pneumatic system)
Interoperability	YES. Fulfillment all applicable TSI and other European Directives
Safety and Signaling system	ERTMS
Train control system	ETCS
Radio system	GSM-R

FERRMED FREIGHT LOCOMOTIVE CONCEPT STUDY



Cab	2 cabs with central desk ensuring safety and comfort of the driver
Noise	TSI CR Noise
Exhaust Emissions	EU 2004/26 Stage IIIB
Others	Incorporation of state-of-the art technologies to improve energy efficiency
	Incorporation of state-of-the-art driving advice systems and operations assistance systems
Materials	About 95% recyclable materials



**Promotion du Grand Axe Ferroviaire de marchandises
Scandinavie-Rhin-Rhône-Méditerranée Occidentale A.S.B.L**

Rue de Trèves 49 – box 7
B-1040 Brussels – BELGIUM
Tél.: +32 (0)2 230 59 50
Fax: +32 (0)2 230 70 35
E-mail: bureau@ferrmed.com

www.ferrmed.com

FERRMED FREIGHT LOCOMOTIVE CONCEPT STUDY